

Ongoing List of Topics:

- URL: <https://pages.mtu.edu/~bamork/EE5223/index.htm>
- Term Project - propose two possible projects, short 2-3 sentence description for each. Submit via Canvas by Mon 9am - give your team number and names of team mates.
- Exercises 6 and 7 coming up, due early March.

Today:

- Short circuit protection in grid systems
 - Directional overcurrent
 - Impedance
- Voltage & Current relationships during faults (cont'd), §3.5-3.10
 - X/R ratio, dc offset, decay of dc offset
 - Relative angles and magnitudes of all Vs & Is during fault
- Basic connections of directional overcurrent (67) relays.
 - Phase relays - each line current is polarized with V_{LL} from other phases.
 - Ground relay - residual current ($3I_{ao}$) polarized with $V_{\text{broken delta}}$ ($3V_{ao}$)
- Excellent Illustrations: figures 3.7 thru 3.10

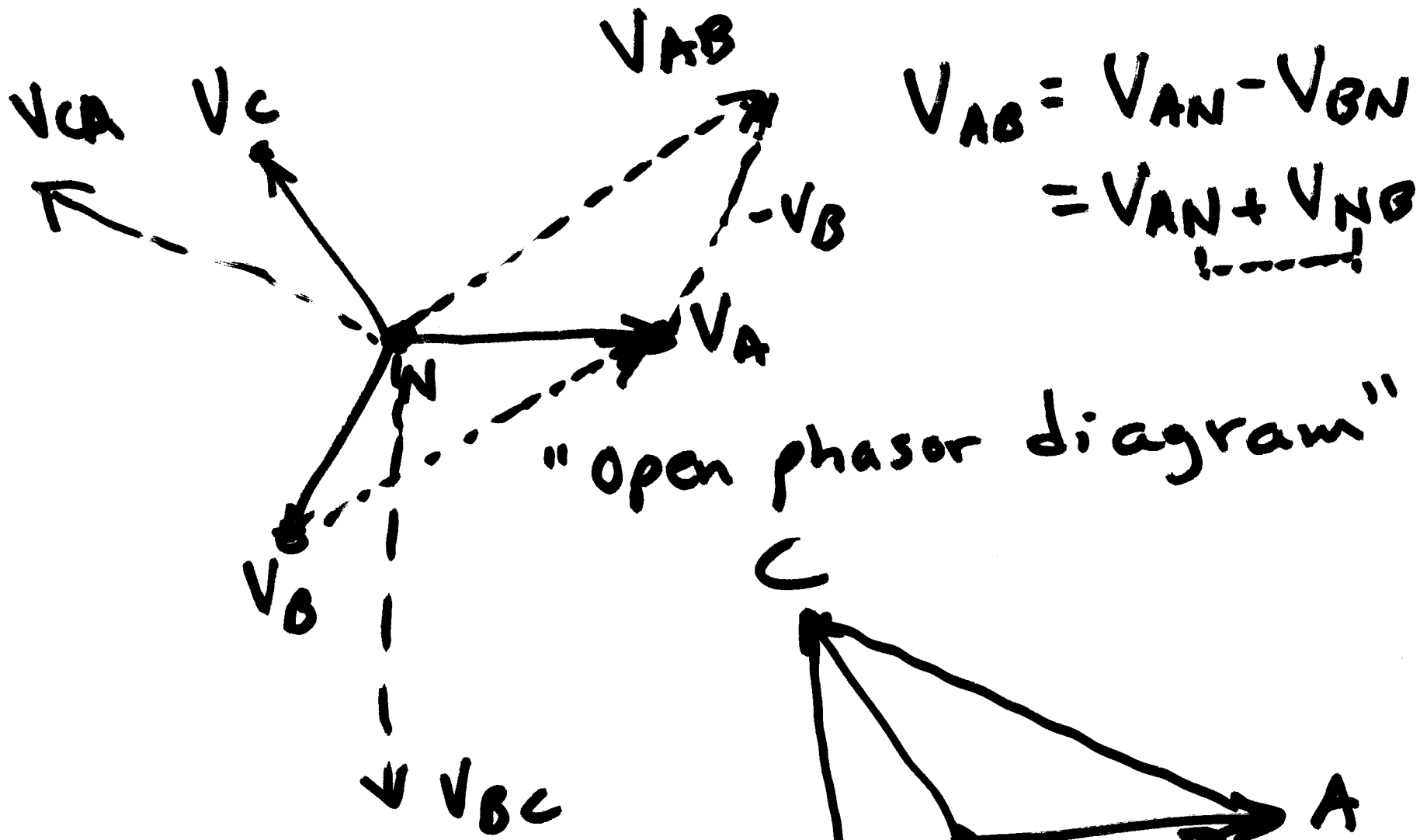

$$V_{AB} = V_{AN} - V_{BN}$$

$$= V_{AN} + V_{NB}$$

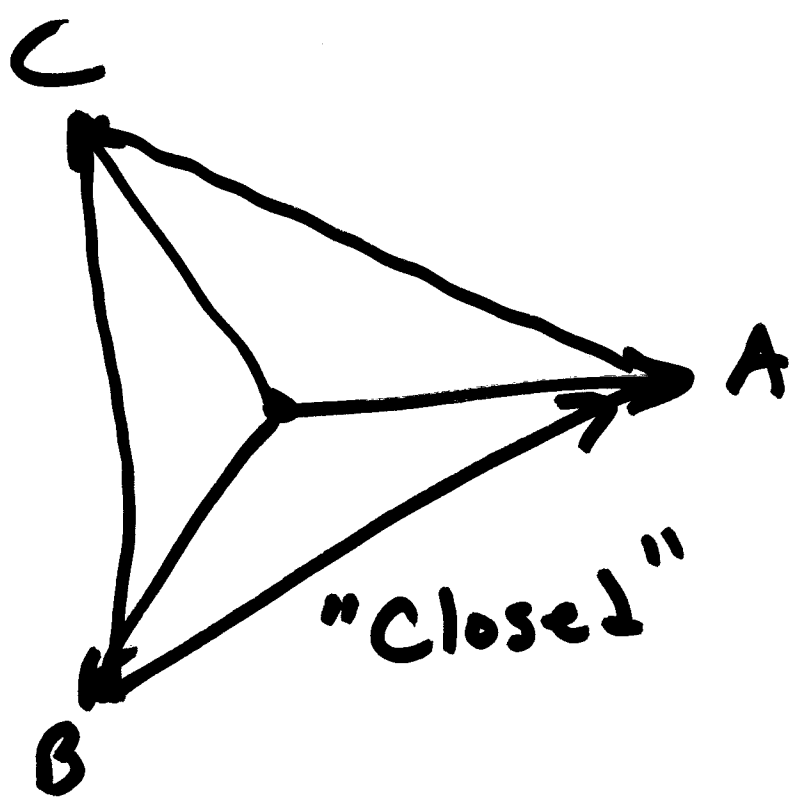

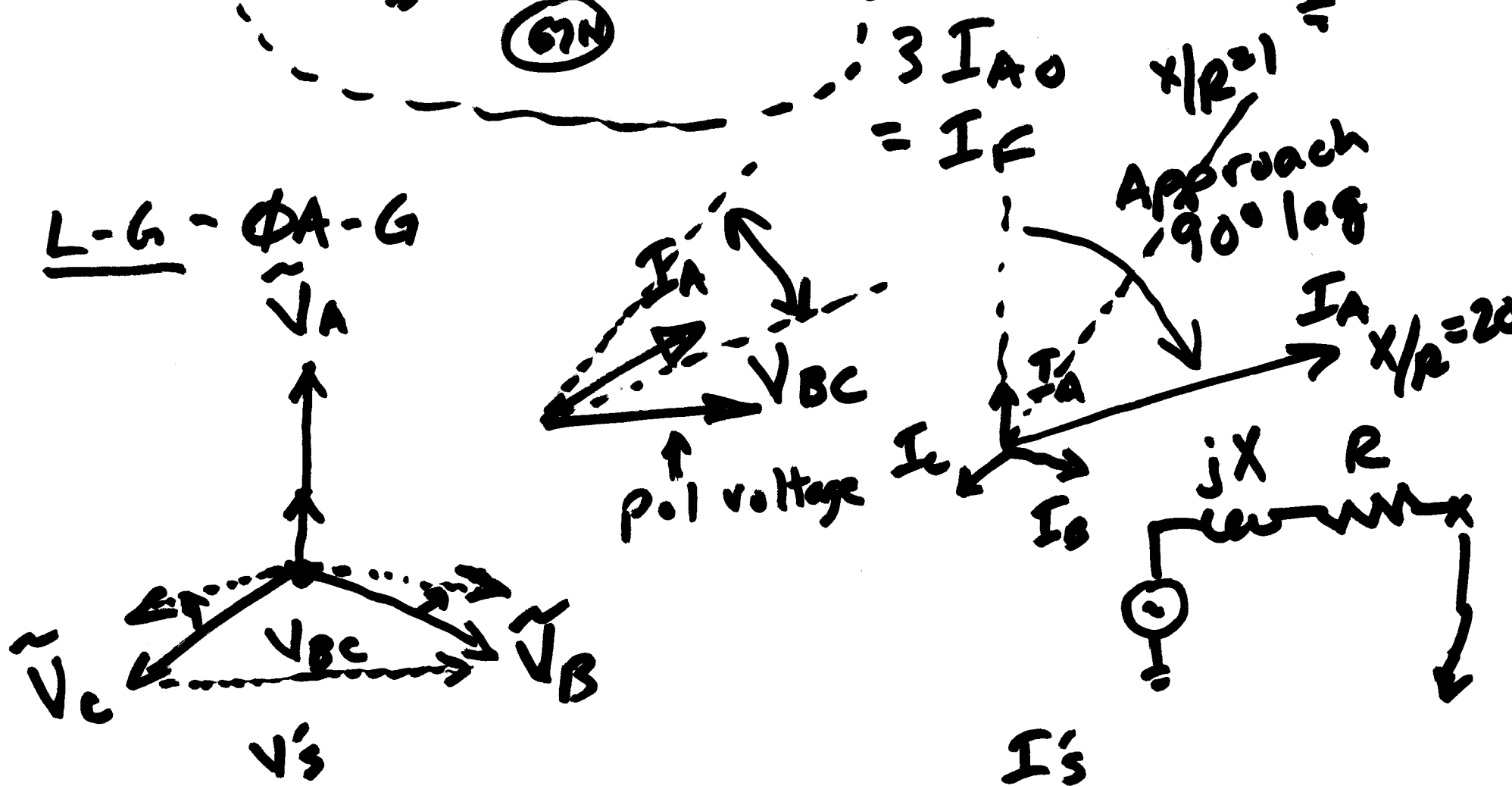
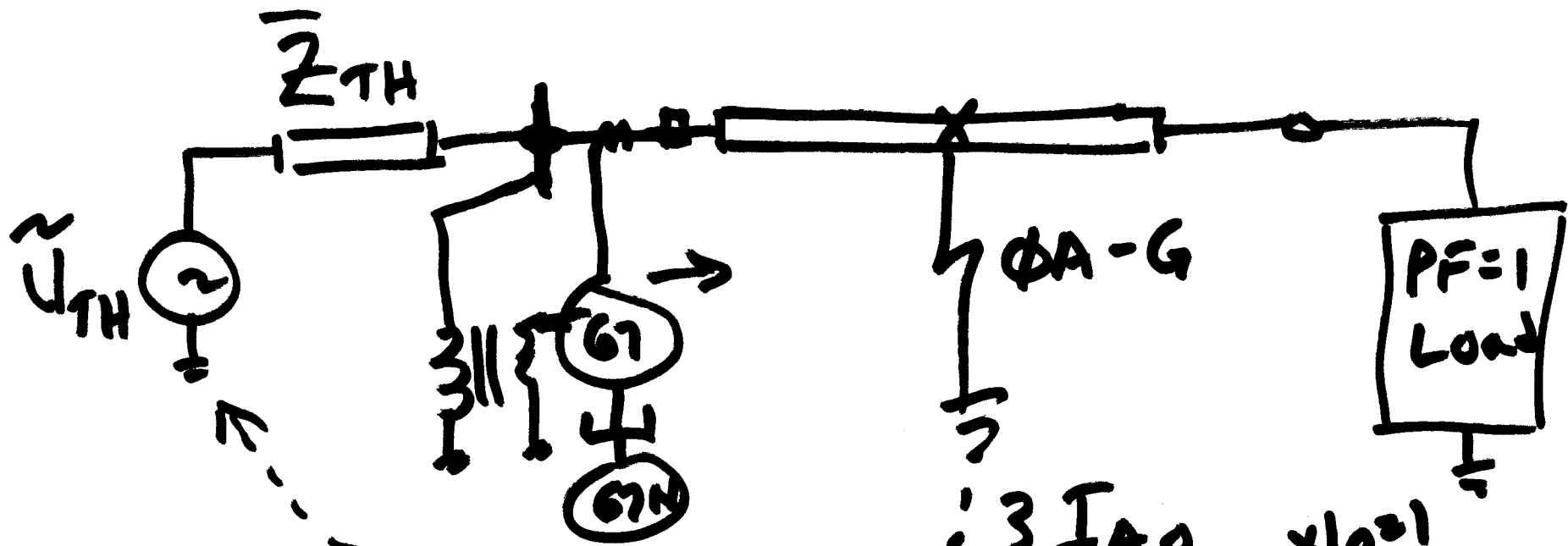

See Fig 3.7 a) $i = \text{max torque}$

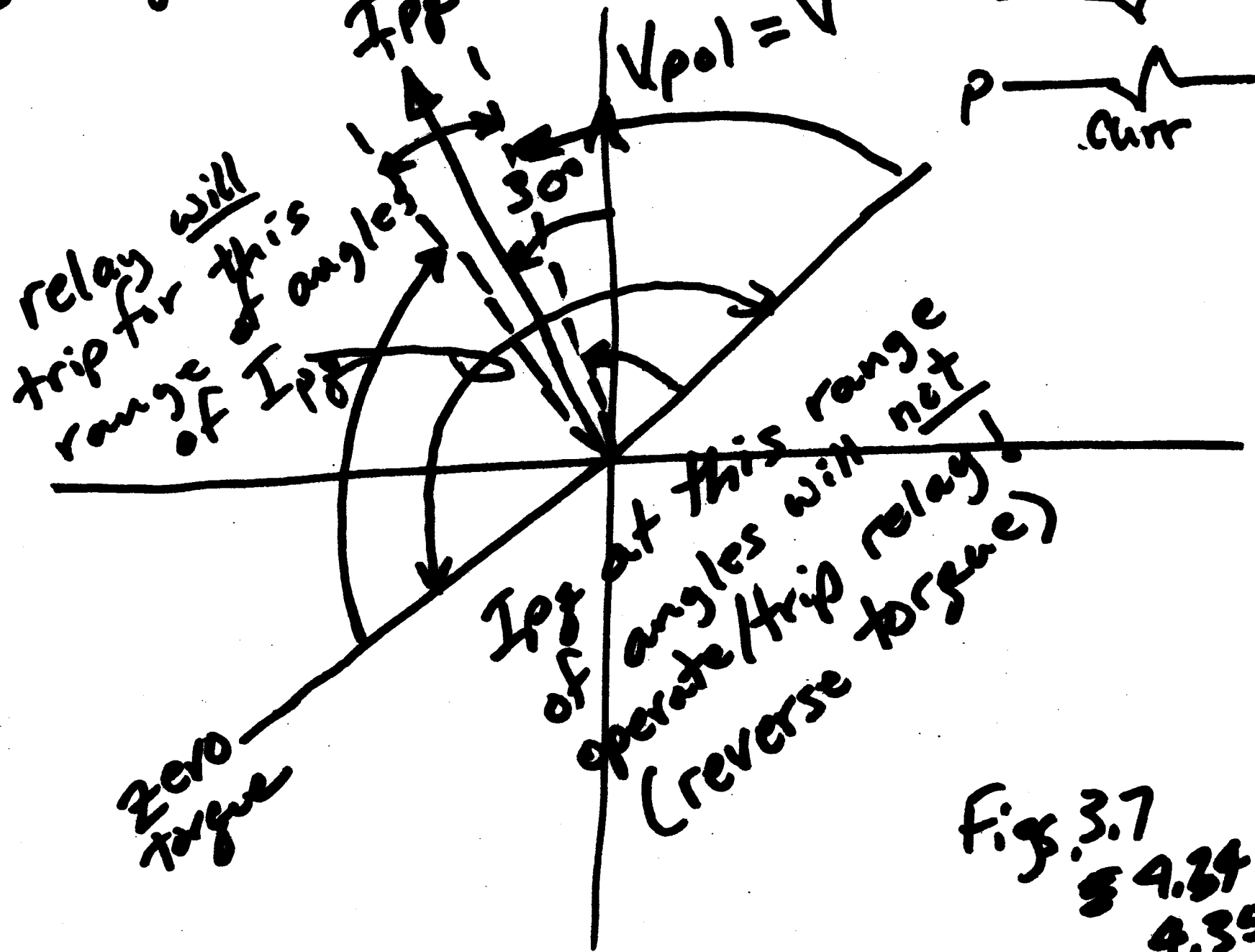
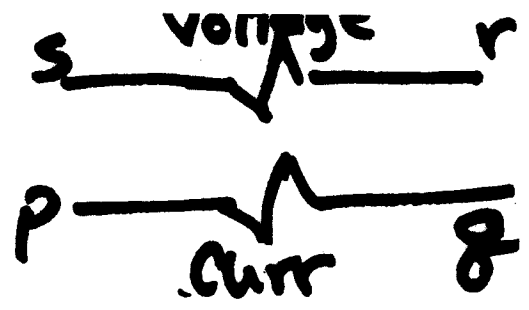
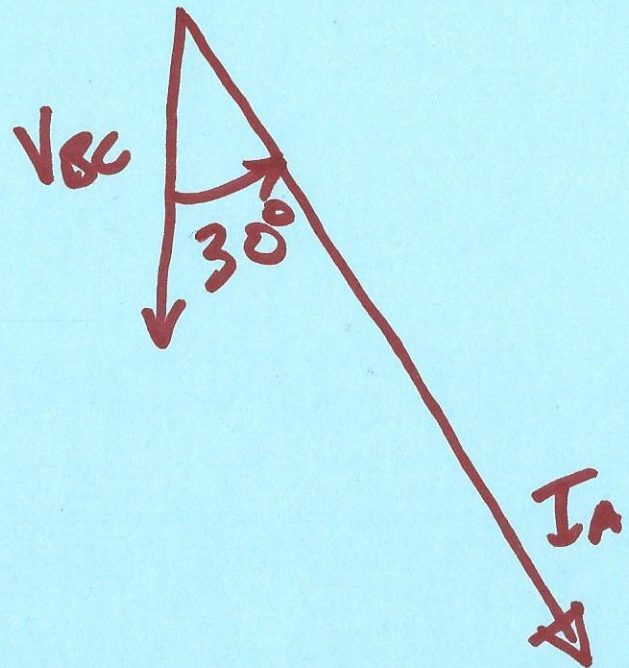
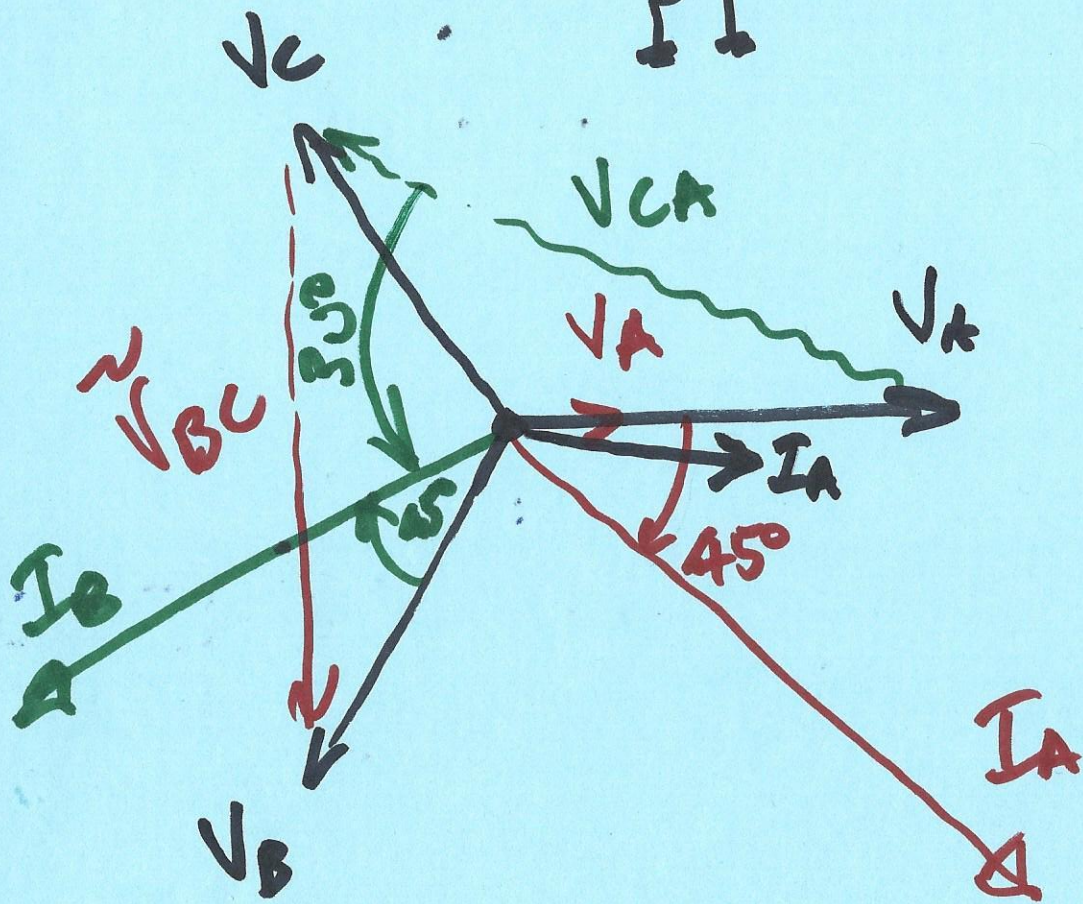
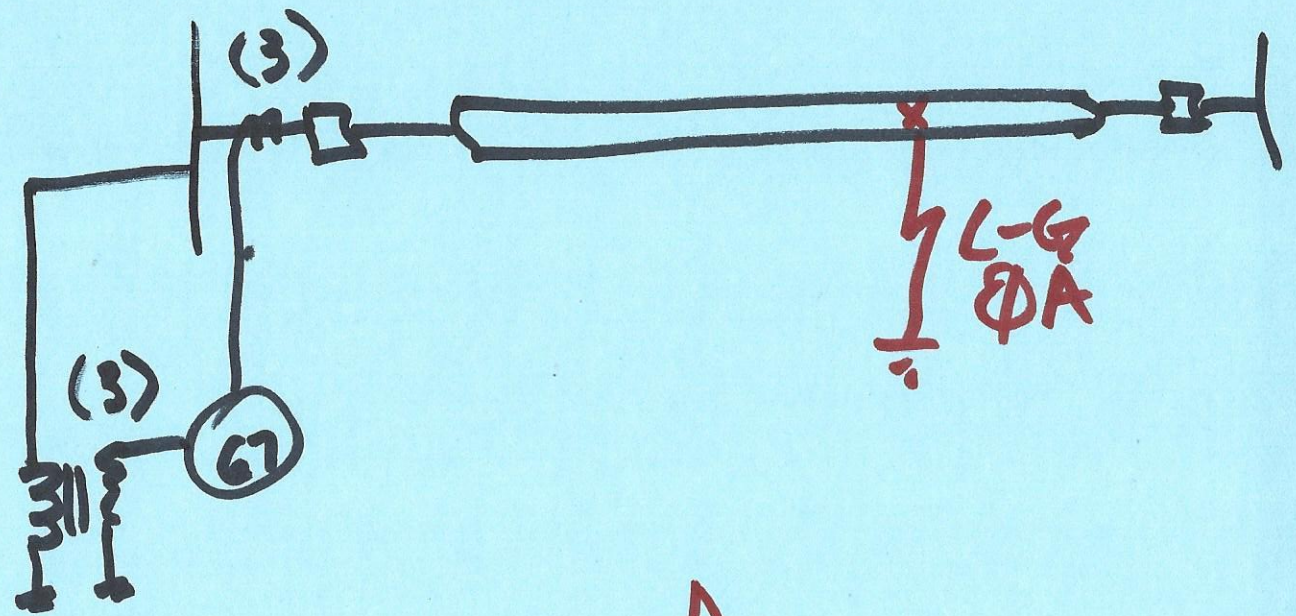

Fig 3.7
 § 4.24
 4.35



the polarity markings diagonally, all as shown on the relay schematics in Fig. 3.7.

The reference quantity is commonly called the "polarizing" quantity especially for ground-fault relaying, where either or both current and voltage polarizing is used. The polarity marks (Fig. 3.7) are small plus symbols (+) placed, as illustrated, above one end of each coil, diagonally as shown, on

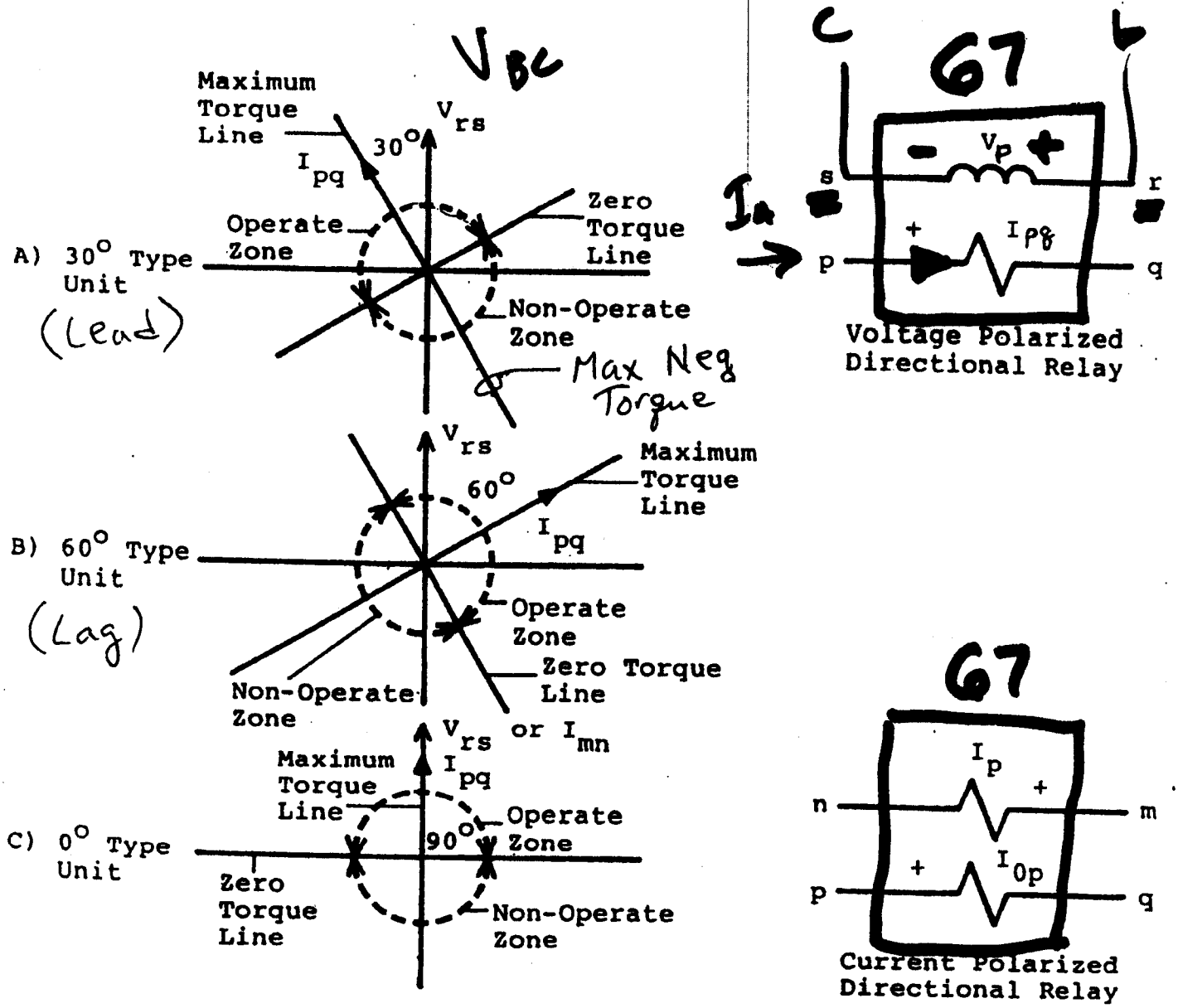
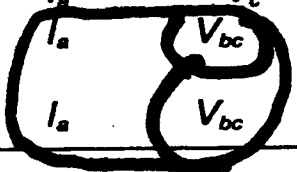

FIGURE 3.7 Typical directional relay characteristics.

TABLE 3.1 Connection Chart for Phase-Fault Directional Sensing

Connection	Unit type	Phase A		Phase B		Phase C		Maximum torque occurs when
		<i>I</i>	<i>V</i>	<i>I</i>	<i>V</i>	<i>I</i>	<i>V</i>	
1 30°	Fig. 3.7C	<i>I_a</i>	<i>V_{ac}</i>	<i>I_b</i>	<i>V_{ba}</i>	<i>I_c</i>	<i>V_{cb}</i>	<i>I</i> lags 30°
2 60° delta	Fig. 3.7C	<i>I_a - I_b</i>	<i>V_{ac}</i>	<i>I_b - I_c</i>	<i>V_{ba}</i>	<i>I_c - I_a</i>	<i>V_{cb}</i>	<i>I</i> lags 60°
3 60° wye	Fig. 3.7C	<i>I_a</i>	<i>-V_c</i>	<i>I_b</i>	<i>-V_a</i>	<i>I_c</i>	<i>-V_b</i>	<i>I</i> lags 60°
4 90°-45°	Fig. 3.7A but maximum torque at 45°	<i>I_a</i>	<i>V_{bc}</i>	<i>I_b</i>	<i>V_{ca}</i>	<i>I_c</i>	<i>V_{ab}</i>	<i>I</i> lags 45°
5 90°-60°	Fig. 3.7A	<i>I_a</i>	<i>V_{bc}</i>	<i>I_b</i>	<i>V_{ca}</i>	<i>I_c</i>	<i>V_{ab}</i>	<i>I</i> lags 60°



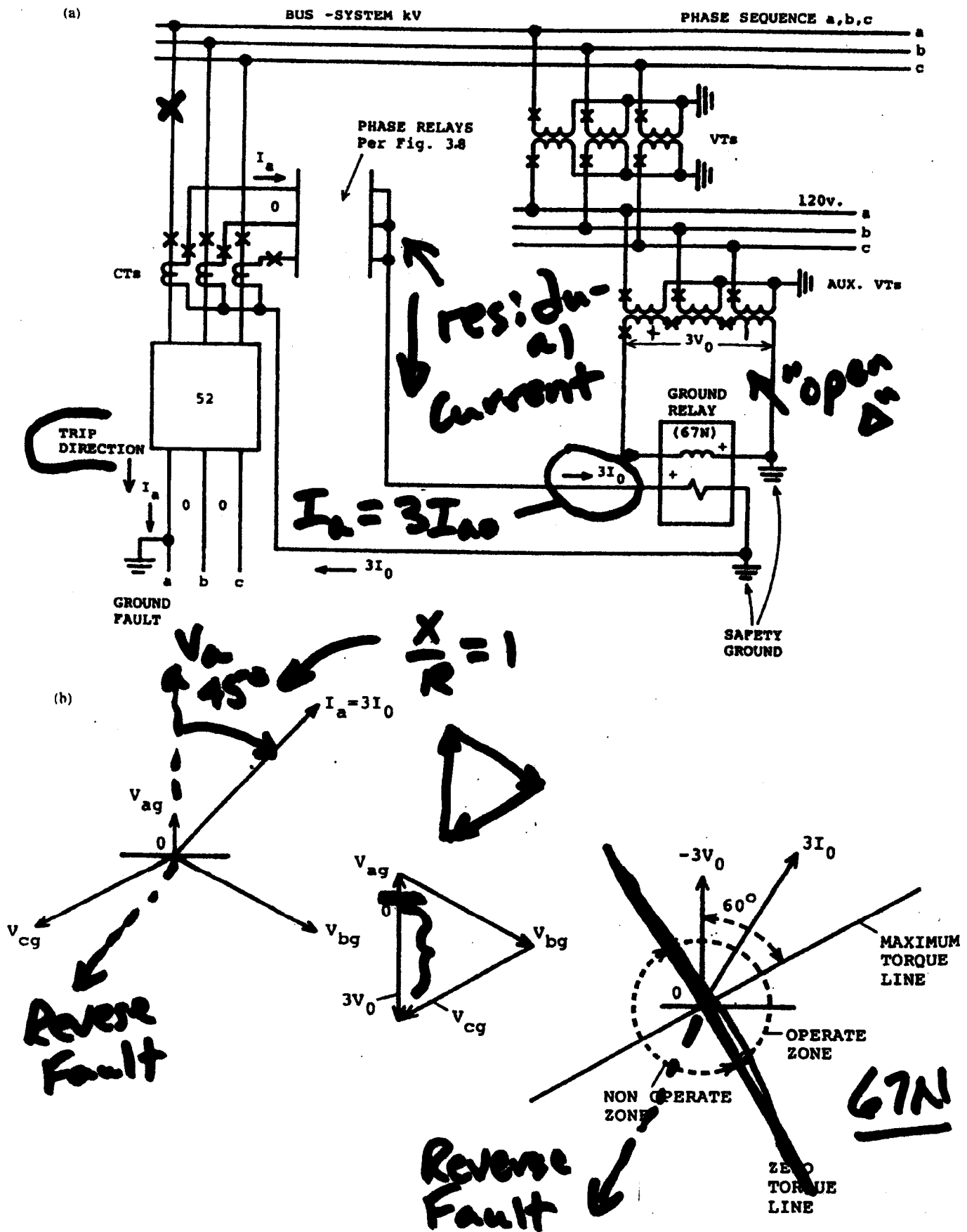
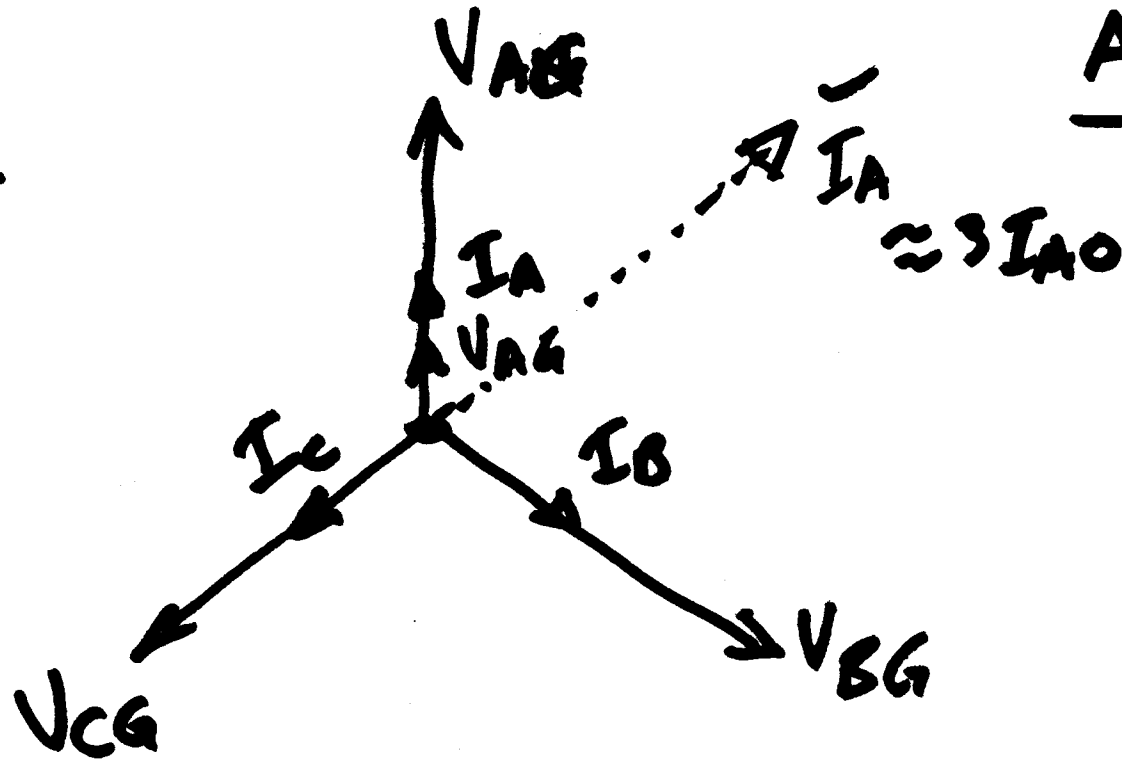

FIGURE 3.9 Typical three-line connections for ground-fault directional sensing with voltage polarization using the 60° unit of Fig. 3.7B.

Before

After



Pol: $\bar{V}_{AG} + \bar{V}_{BG} + V_{CG} = \underline{\underline{3V_{A0}}}$

$$I_{in} = \bar{I}_A + I_B + I_C \\ \approx \bar{I}_A = 3 I_{A0}$$

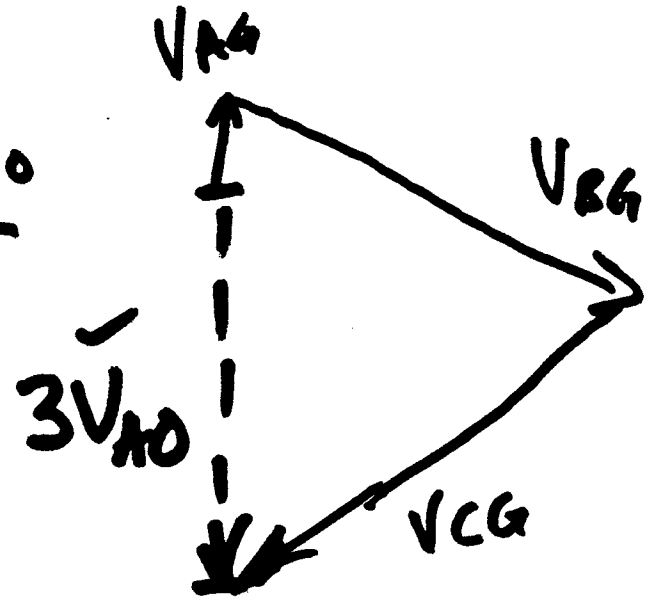

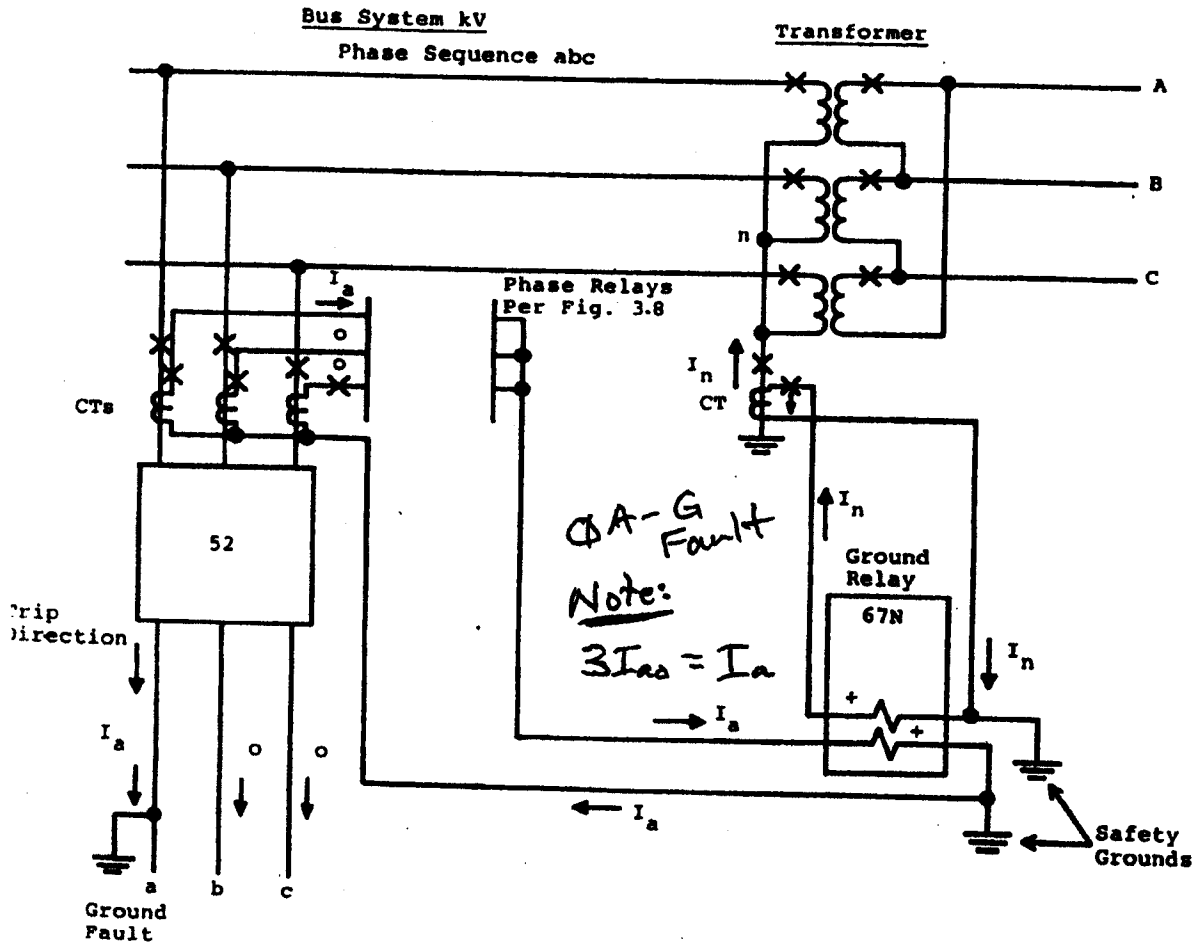

FIGURE 3.10 Typical three-line connections for ground-fault directional sensing with current polarization using the 0° unit of Fig. 3.7C.

uses the current flowing into the fault will be essentially in phase with the current flowing up the transformer bank neutral, so the 0°-type ground relay with characteristics, as shown in Fig. 3.7C, is applicable and is the one used in Fig. 3.10 connections.

To illustrate and to emphasize that the polarity marks on the current transformers do not have to be connected to the polarity-marked terminal of the relay, the fault I_a current from the CTs on the line have been connected arbitrarily so that I_a flows from nonpolarity to polarity on the relay coil. Therefore, the polarizing secondary current I_n must be connected from nonpolarity to polarity when the primary fault I_n flows up the neutral of the transformer.

With the currents I_a and I_n in phase, maximum operating torque will occur as in Fig. 3.7C. Operation is still possible, as one current leads or lags almost 90° from the other, as long as the magnitudes are higher than the required pickup values for the directional unit.

G1: (W) KRD-4
G2: BEL-67
G3: SEL-311L

} 67 relays

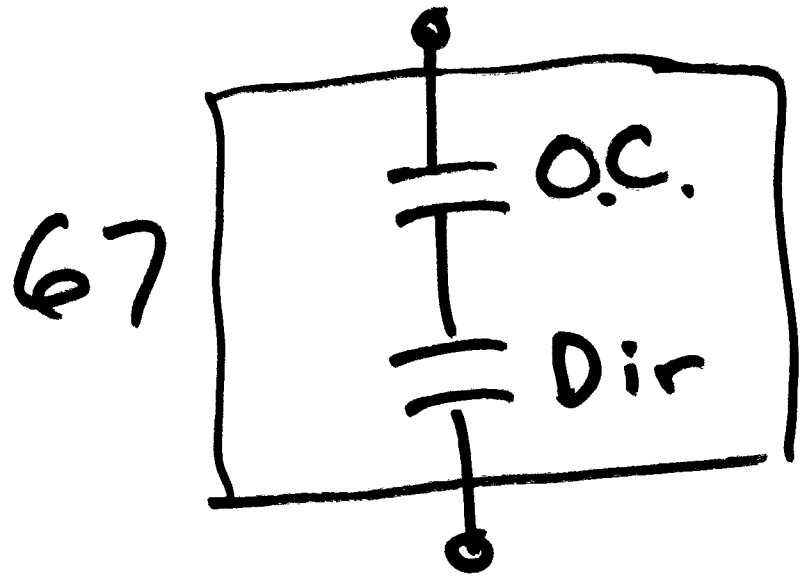

September, 1990
Supersedes DB 41-130D, pages 1-4,
dated July, 1989
Mailed to: E, D, C/41-100A

Device Number: 67N

Types KRD-4 and KRQ Directional Overcurrent Ground Relays

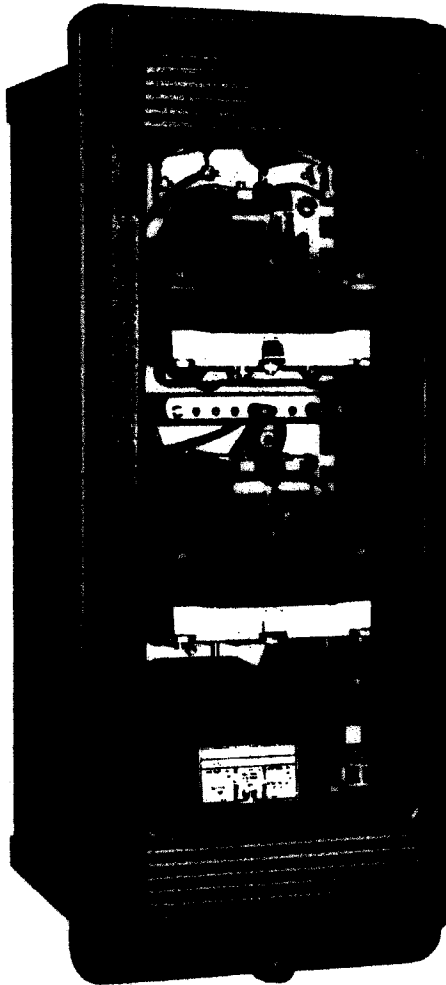

KRD-4

The directional unit compares the phase angle relationship between the ground fault current and the polarizing quantity to produce contact-closing torque for faults in the trip direction, and contact-opening torque for faults in the non-trip direction. Relay operation occurs when both the directional unit and the instantaneous overcurrent unit close their contacts. The fault current must therefore be greater than the tap setting of the overcurrent unit.

Type KRQ

The KRQ relay is a high-speed directional overcurrent ground relay in which the directional unit operates on negative sequence current and voltage, and the over-current unit operates on residual or ground current.

The phase angle between negative sequence voltage and negative sequence current is used for directional discrimination. Negative sequence polarization is applied as follows: (1) where zero sequence voltage or polarizing current is not available or the current is not a reliable source, or (2) where incorrect zero sequence polarization of directional units results from mutual induction between transmission lines.

The negative sequence current and voltage are obtained by means of self-contained negative sequence filters connected between the directional unit and the current and potential transformers.

The KRQ relay is for use at locations where the present equipment or system conditions do not permit the use of the conventional types of directional ground relays operating entirely on residual current and voltage.

It is applicable for ground protection at underground substations or grounded systems where only two potential transformers are available, or where the potential transformers are on the low-tension side of a wye-delta or delta-wye power transformer bank.

Application

Types KRD-4 and KRQ relays are high-speed, directional overcurrent relays. They are used for the detection of ground faults on transmission lines, feeder transmission lines, and feeder circuits.

They can also be used, without modifica-

tion, to provide directional ground fault protection in K-Dar carrier relaying schemes.

Type KRD-4

This dual polarized relay can be polarized from a potential source, a local ground source, or from both simultaneously.

Construction

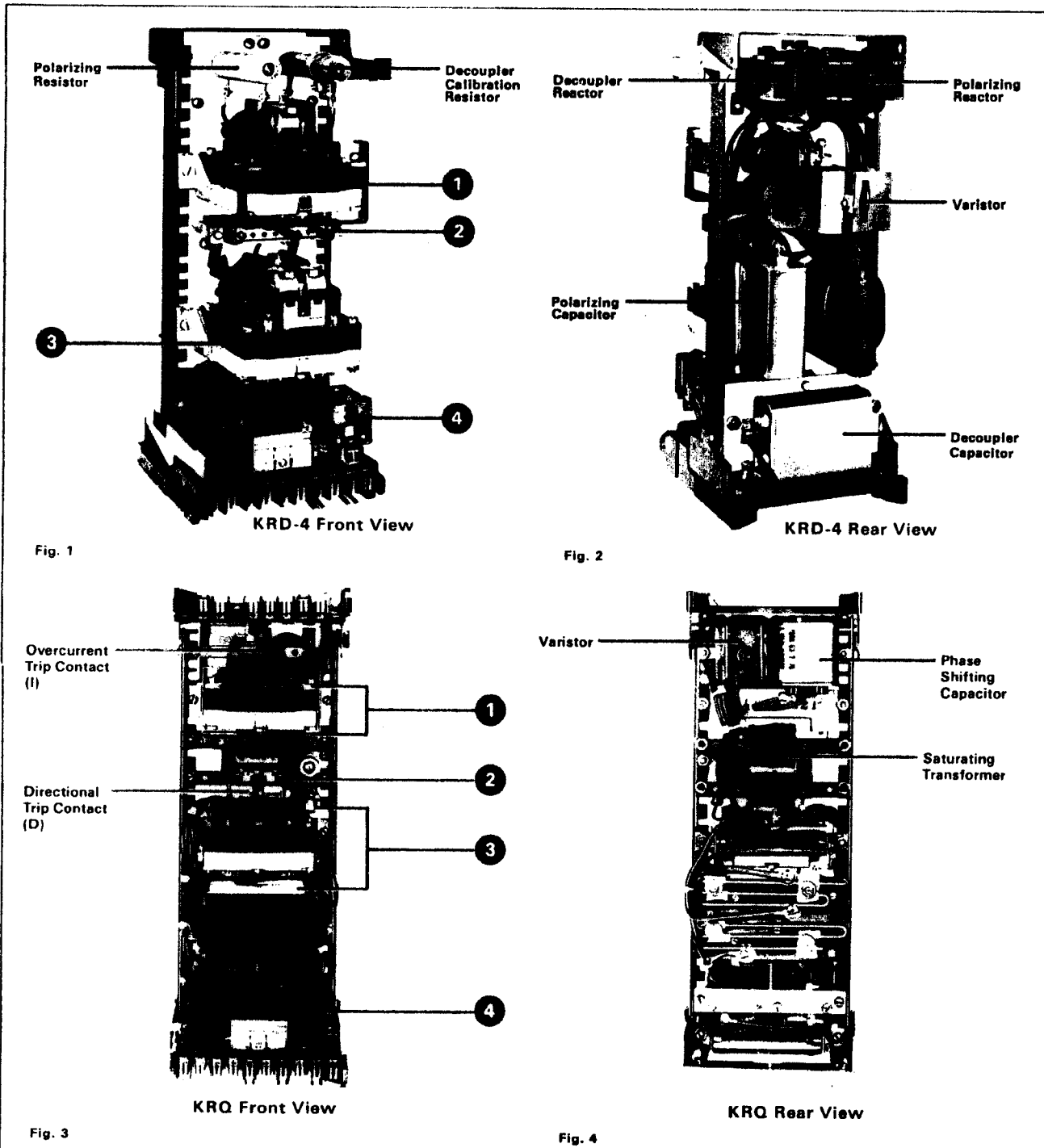

① Overcurrent Unit (I)

The ground instantaneous overcurrent section consists of an induction cylinder unit with moving and stationary contact, phase shifting capacitor, varistor, saturating transformer with a tapped primary winding and a secondary winding, and a tap block for current pickup settings.

A varistor is connected across the secondary winding to reduce the voltage peaks applied to the induction unit and to the phase shifting capacitor.

② Tap Block

The primary winding is tapped, and these taps are brought out to a tap block for ease in changing the pick up of the overcurrent unit. By using a tapped transformer, the relay can provide approximately the same energy level at a given multiple of pickup current for any tap setting, resulting in one time curve throughout the range of the relay.

③ Directional Unit (D)

KRD-4

The KRD-4's directional unit consists of an induction cylinder unit, phase shifting network, and a die-coupling network.

Since this single unit can be polarized from a potential source, from a local ground source, or from both simultaneously, a simplified trip circuit and one, instead of two, back contacts can be used in the overcurrent torque control circuit.

KRQ

The KRQ directional unit is a product induction cylinder type, which operates on the interaction between the polarizing circuit flux and the operating circuit flux.

④ Indicating Contactor Switch (ICS)

When the dc operated ICS is energized, the moving contacts bridge two stationary contacts, completing the trip circuit.

Characteristics

Current Ranges

Both the KRD-4 and the KRQ relays are available in the following current ranges:

Range: Amps	Taps [ⓐ]					
0.5-2	0.5	0.75	1.0	1.25	1.5	2.0
1-4	1.0	1.5	2.0	2.5	3.0	4.0
2-8	2.0	3.0	4.0	5.0	6.0	8.0
4-16	4.0	6.0	8.0	9.0	12.0	16.0
10-40	10.0	15.0	20.0	25.0	30.0	40.0

[ⓐ] Tap value is the minimum current required to just close the relay.

Torque Angle (KRD-4)

When the relay is potential polarized, maximum torque angle occurs when operating current lags polarizing voltage by approximately 65 degrees.

When current polarized, maximum torque angle occurs when operating current is in phase with the polarizing current.

Trip Circuit

The main contacts of both the KRD-4 and KRQ relays will safely close 30 amperes at 250 volts dc, and the seal-in contacts of the ICS unit will safely carry this current long enough to trip a circuit breaker.

The ICS has a pickup of approximately 1 ampere. Its dc resistance is 0.1 ohms.

Directional Unit Sensitivity

Polarizing Quantity	Minimum Pickup Values		Phase Angle Relationship
	Volts	Amperes	
Voltage	1	0.6	I lagging V by 65 degrees
	1	1.4	I in phase with V
Current	..	0.5	in-phase

Energy Requirements

KRD-4: See Instruction Leaflet 41-137.3.
KRQ: See Instruction Leaflet 41-164.

Further Information

List Prices: PL 41-020

Technical Data: TD 41-025

Instructions:

Type KRD-4, IL 41-137.3

Type KRQ, IL 41-164

Renewal Parts: RPD 41-963

Flexitest Case Dimensions: DB 41-076

Contact Switches: DB 41-081

Other Protective Relays:

Application Selector Guide, TD 41-016



December, 1990
Supersedes TD 41-020, Types KRD-4 and
KRQ on page 35, dated November, 1987
Mailed to: E, D, C/41-100A

Type KRD-4 and KRQ Directional Overcurrent Ground Relays

Overcurrent, Instantaneous, Directional, Single Phase (Device Number: 67N)

Type Time Curve and Contacts	Application	Indicating Contactor Switch ^①	Current Range: Amps Ac	Relay Data		
				Internal Schematic	Style Number	Case Size
KRD-4 ^① ⊙ Instantaneous	Ground Detection 208 volts/30 sec	1.0 amp dc	0.5-2.0	629A509	293B307A09 293B307A10 293B307A11	FT-31
			1-4 2-8			
Spst-cc		0.2/2.0 amp dc	0.5-2.0	762A542	293B307A12 293B307A13 293B307A14 293B307A16 293B307A15	
			1-4 2-8 4-16 10-40			

Overcurrent, Instantaneous, Directional, Negative Sequence (Device Number: 67N)

Type Time Curve and Contacts	Application	Indicating Contactor Switch ^①	Current Range: Amps Ac	Relay Data		
				Internal Schematic	Style Number	Case Size
KRQ Instantaneous	Ground Detection	1.0 amp dc	0.5-2.0	184A546	774B232A13 774B232A09 774B232A10 774B232A11 774B232A12	FT-42
			1-4 2-8 4-16 10-40			
		0.2/2.0 amp dc		188A308	774B232A15 774B232A17 774B232A18	

Potential Polarizing Transformers, Single Phase (Product Bulletin 42-871 for dimensions)^②

Volt-amps	Frequency, Hertz	Primary Volts		Secondary Volts	Compensated at:		Connections Primary/Secondary	Style Number
		Line-to- Line	Line-to- Neutral		Volt- amps	Power Factor		
50	50/60	115	66.5	115	25	100%	Connect wye/broken delta	9626A06G01 9626A06G02 9626A06G03
		200	115	66.5				
		200	115	115				

① 50-Hertz relays and auxiliaries can be supplied at same price. Order "Similar to Style Number, except 50 Hertz".

② See potential polarizing transformers, this page.

③ ICS: Indicating Contactor Switch (dc current operated) having seal-in contacts and indicating target which are actuated when the ICS coil is energized at or above pickup current setting. Suitable for dc control voltages up to and including 250 volts dc. Two current ranges available: (1) 0.2/2.0 amps dc, with tapped coil. (2) 1.0 amp dc, without taps.

Rating of ICS unit used in specific types of relays is shown in price tables. All other ratings must be negotiated.

When ac current is necessary in a control trip circuit, the ICS unit can be replaced by an ACS unit.

The ACS unit may be supplied in place of an ICS unit at no additional cost. Specify system voltage rating on order.

④ Refer to LVIT Sales, Low Voltage Instrument Transformer Division, Pinetops, NC, for price and shipment.

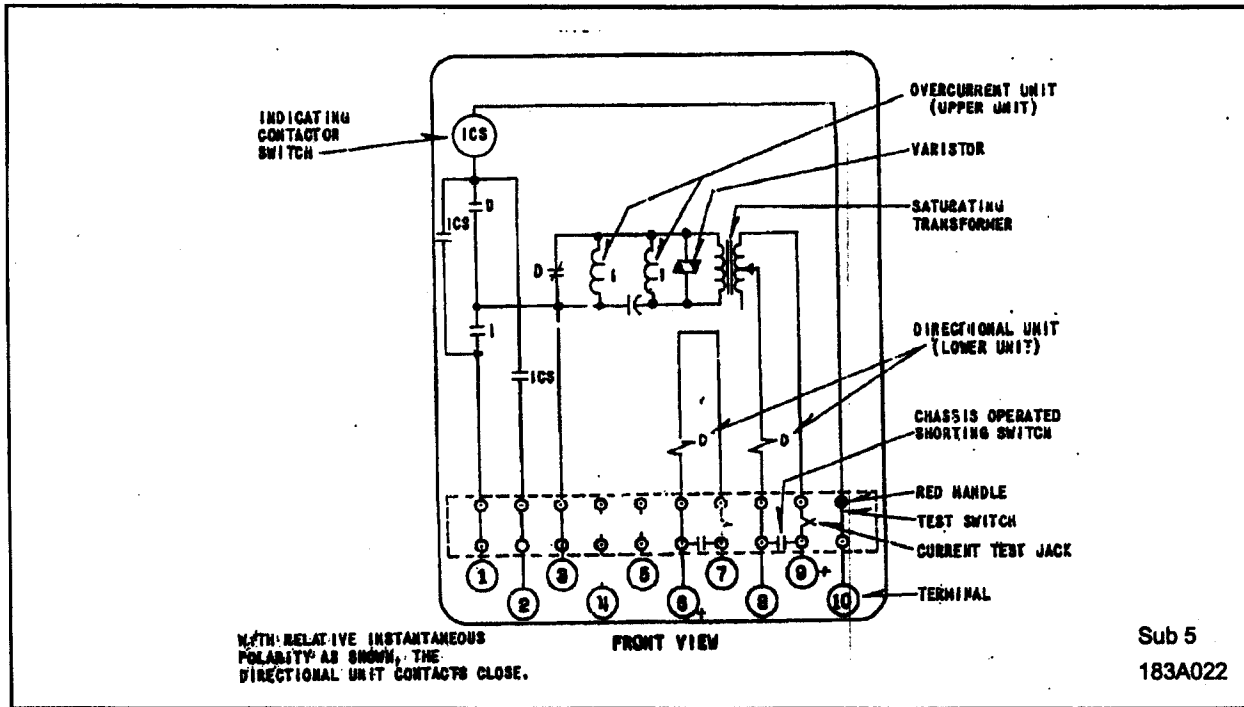

Figure 4: Internal Schematic of the Type KRC Relay in the FT-31 Case

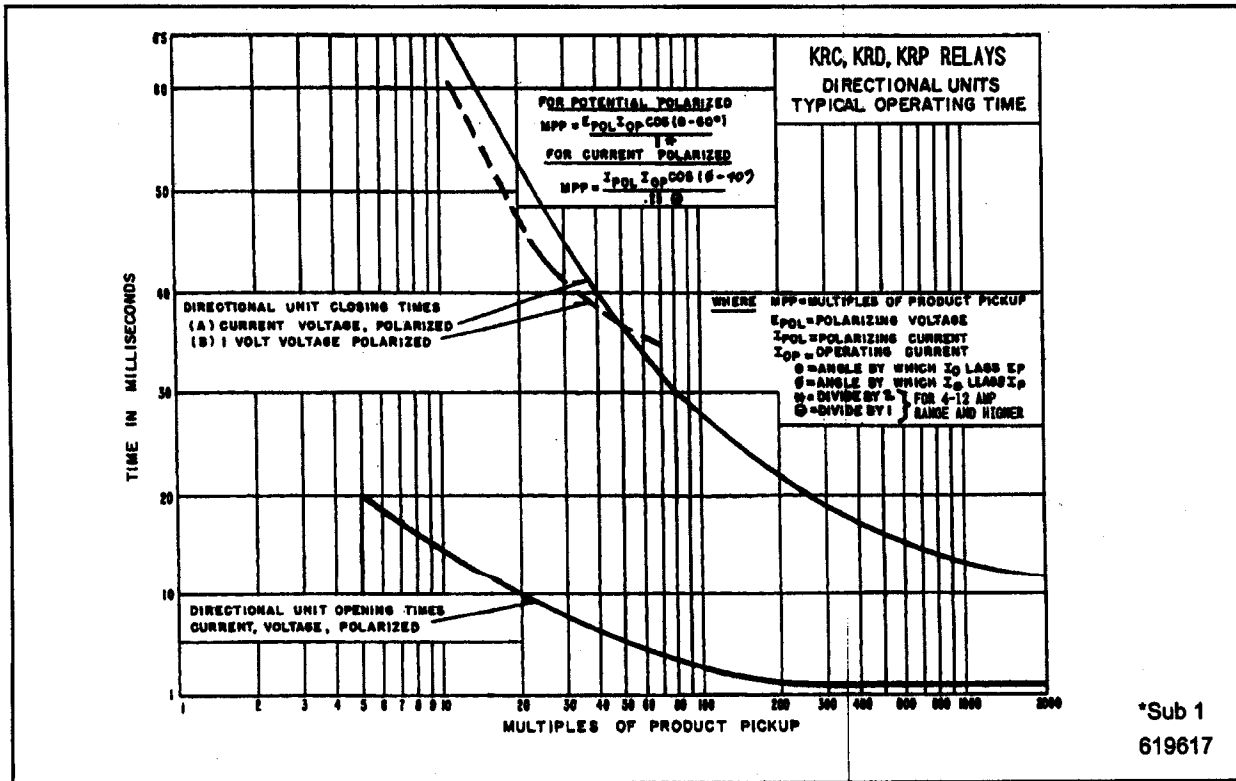

Figure 5: Typical Operating Times for the D-Unit of the Type KRD, KRP, and KRC Relays

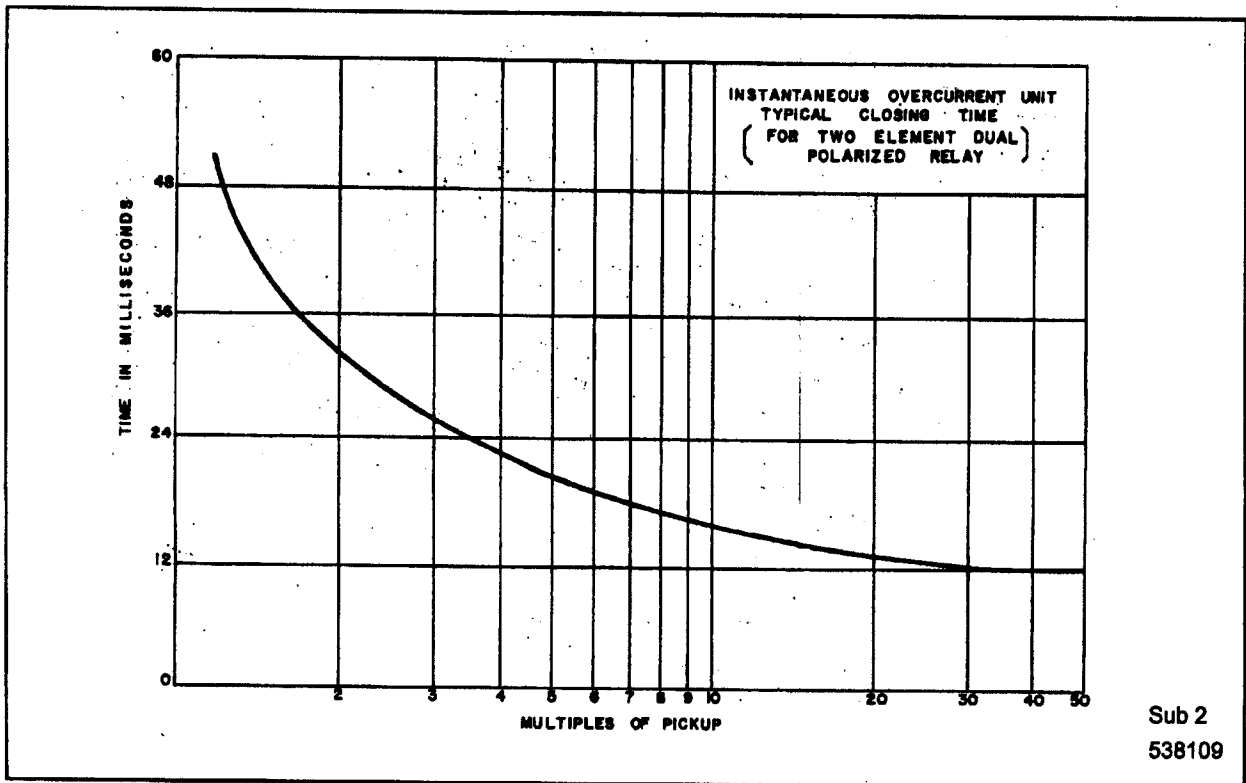
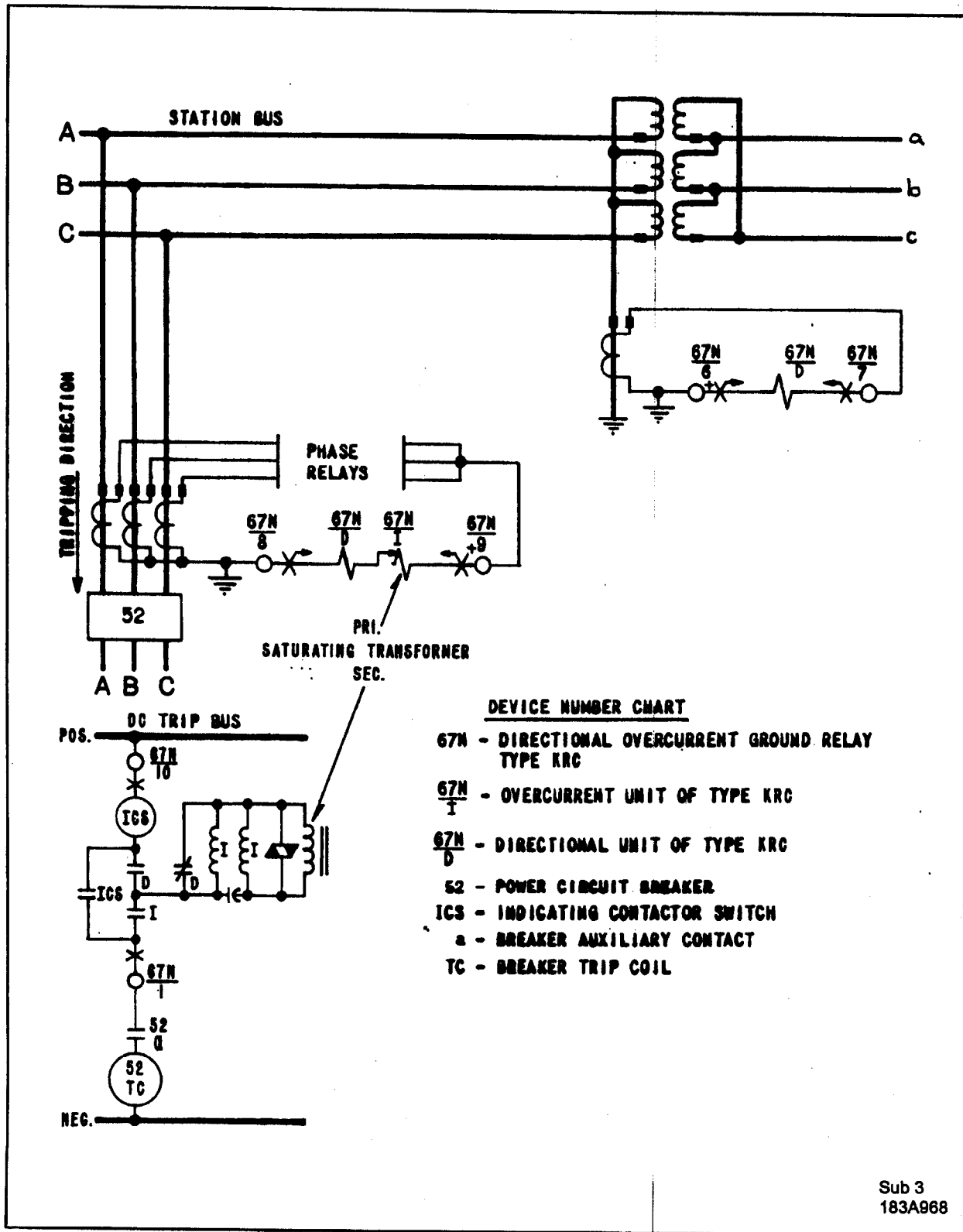

Figure 6: Typical Operating Times for the D-Unit of the Type KRD, KRP and KRC Relays



Sub 3
183A968

Figure 7: External Schematic of the Type KRC Relay

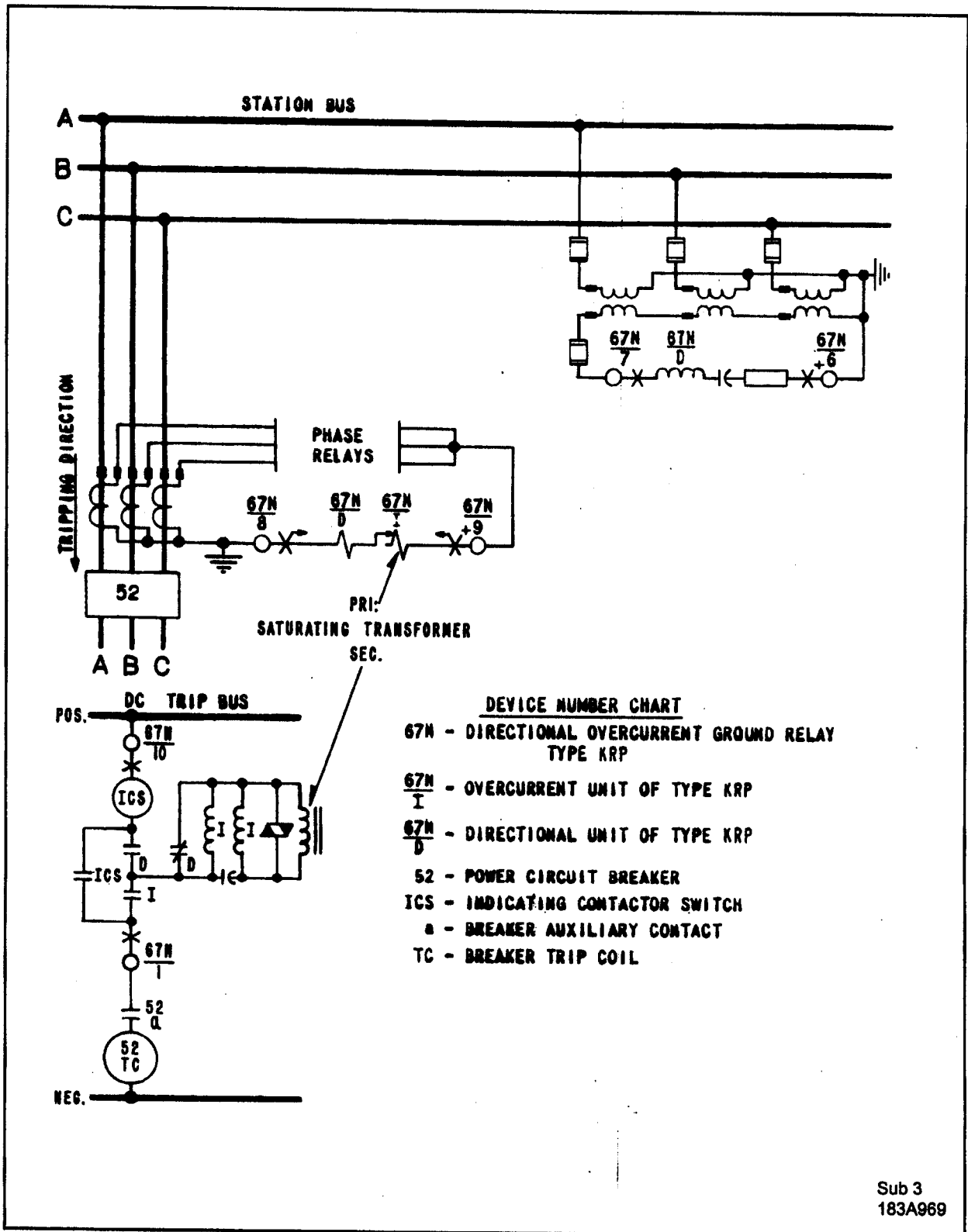

Figure 8: External Schematic of the Type KRP Relay

Sub 3
183A969

G2

Basler Electronic
Relay

(Refer to Figure 5-13.)

$$\text{Phase} = + 90 - | \text{CHARACTERISTIC ANGLE setting} | - | \beta |$$

Where:

- Phase = phase of the applied current relative to the applied voltage;
- β = desired LIMITED REGION OF OPERATION setting;
- + angle = leading current;
- angle = lagging current.

Step 5. Slowly rotate the LIMITED REGION OF OPERATION control CCW until the INHIBIT LED just illuminates.

Verifying Relay Settings

A verification of the directional setting should now be performed.

Step 6. Vary the applied current phase angle through 360° and record the angle values at which the appropriate phase INHIBIT LED turns ON and OFF. Plot the results on a polar coordinate graph for future reference.

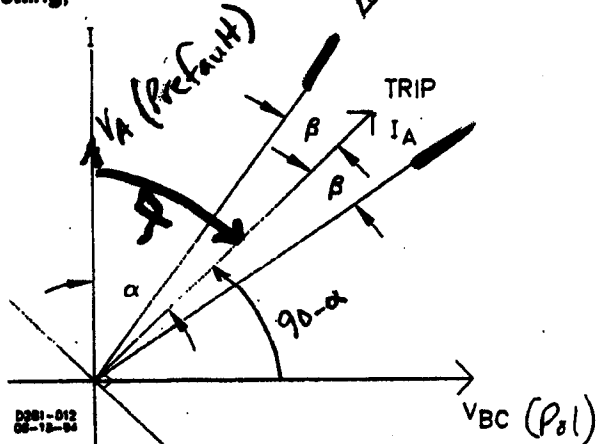

Figure 5-13. Limited Region Of Operation Setting

SETTING THE RELAY - AN EXAMPLE

One method of setting the relay is described here. There are other methods that may be used as well. All methods involve similar steps and equipment.

Example Defined

Before the relay can be set, the required settings need to be defined. A typical example follows.

- Time overcurrent pickup: - 5.7 A
- Curve shape: - Very Inverse
- Time delay setting: - 5.2 seconds at 28.5 A
- Instantaneous overcurrent pickup: - 39.9 A
- Line impedance angle: - α ? $\alpha = \angle V_A - \angle I_A = 60^\circ$
- Limited range of operation: - β ? $\beta = 45^\circ$

The relay that has been selected for this application is a BE1-67, style number B1E-Z2Y-B1N6F.

Before applying sensing inputs to the relay, a few adjustments are necessary.

Step 1. Since the relay includes the Z2 timing option, the characteristic curve needs to be selected. This is accomplished by removing the front panel and adjusting the TIME OVERCURRENT CHARACTERISTIC CURVE SELECTOR switch to position 6.

Step 2. Because the time overcurrent pickup is 5.7 amperes, the sensing current input for the relay will need to be connected for the HIGH range. Adjust the TAP RANGE plate on the front panel to display the word HIGH. Verify that the current connections to the relay are on terminals 7 and 8 (Phase A), 14 and 15 (Phase B), and 17 and 18 (Phase C). Terminals 9, 13, and 16 should not be connected.



G3

SEL-311L Line Current Differential Protection & Automation System

Protect Lines With Easy-to-Use Current Differential Relays

IEC 61850
Compatible

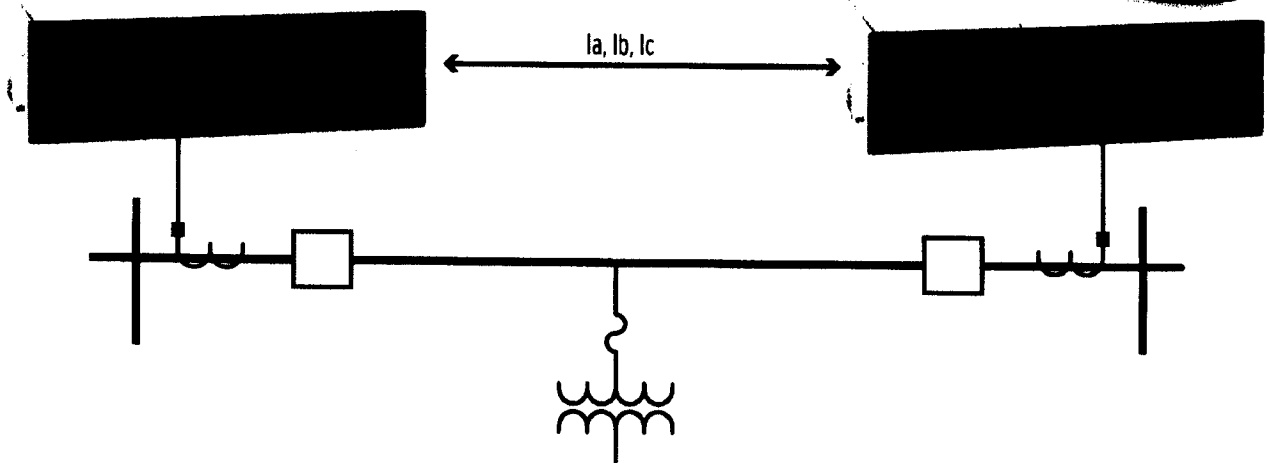

*Use SEL-311L Line Current
Differential Relays with full-scheme
backup for easy-to-apply high-speed
line protection.*

Features and Benefits

- **Protect**
Apply single-pole or three-pole subcycle current differential protection. Reduce protection system costs by using built-in distance and/or overcurrent backup functions.
- **Simplify**
Innovative operating characteristic makes settings easy. No fault studies are required for most differential applications.
- **Optimize**
Use single or dual channels for reliability. Apply on two- or three-terminal lines with or without tapped lines.
- **Monitor**
Incorporate synchrophasor measurements into wide-area protection and control systems. Use high-accuracy time correlation to improve event report analysis.
- **Automate**
Reduce total project construction and operation costs by integrating four-shot recloser and relay logic operators into your automation system. Use serial or Ethernet communications to improve station integration.

**SYNCHROPHASOR
READY™**

Making Electric Power Safer, More Reliable, and More Economical®

Functional Overview

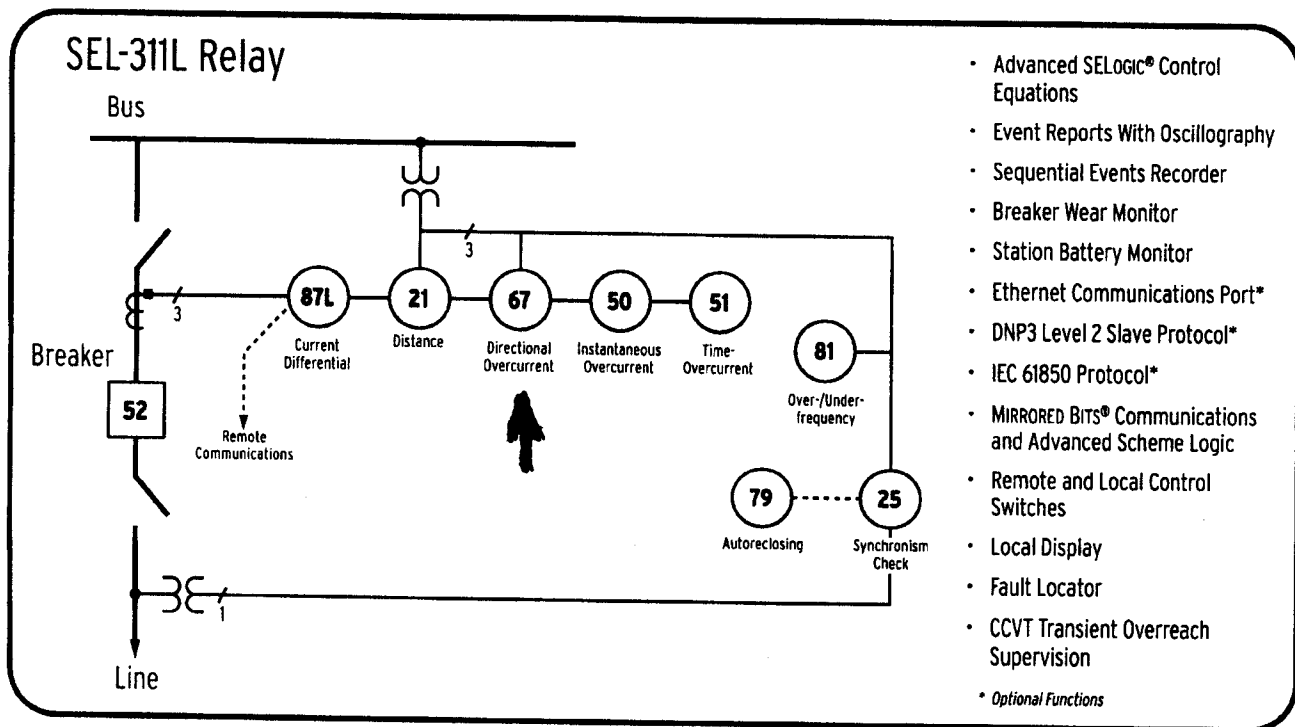

Superior, Sensitive, and Simple

- The SEL-311L Relay uses a vector ratio of the local and remote phase and sequence currents (Alpha Plane restraint) to provide high-speed protection, independent of line loading, CT saturation, or tapped load.
- Proven negative-sequence elements provide sensitivity for unbalanced faults. High-impedance fault detection gives secure operation for faults below load current or line-charging current levels.

- Use factory default settings for basic line current differential applications. Configure the channels, select the CT ratios, and the SEL-311L Relay is ready for operation.
- Improve stability for critical systems using optional single-pole differential elements for high-speed fault clearing.

Alpha Plane Restraint and Operate Regions

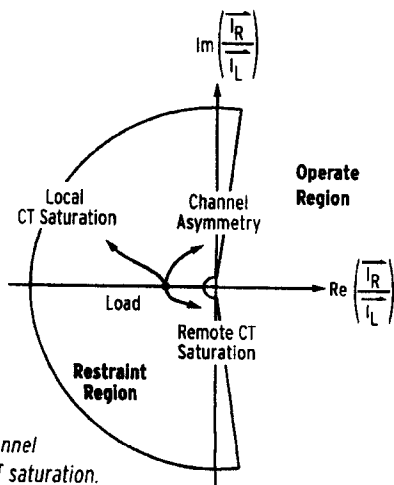

Differential Trip Speed

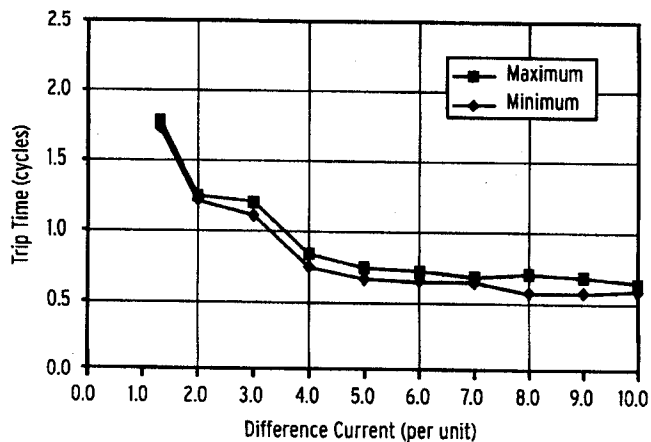

High-speed protection.

Full Scheme and Overcurrent Backup Included

- Backup protection in the SEL-311L Relay is identical to the complete functionality of the SEL-311C Relay, including four zones of positive-sequence, memory-polarized distance relaying. Sufficient memory time during zero-voltage faults allows distance element backup on short lines. Best Choice Ground Directional Element™ overcurrent relaying automatically selects the optimal directional unit for changing system conditions. Use MIRRORED BITS® communications or a traditional channel interface for independent, communications-assisted tripping (e.g., POTT and DCB).
- Set independent backup upon loss of differential channels.
- A complete four-shot recloser with synchronism check is included. Use SELogic® control equations to change the protection based on shot count. Use local, remote, and latched control switches to customize the protection system. Change the reclosing logic based on fault type or an external input.
- Six levels of overfrequency and/or underfrequency are included for load shedding and restoration. Combine with protective functions using SELogic control equations to optimize relay response, preserving system integrity.

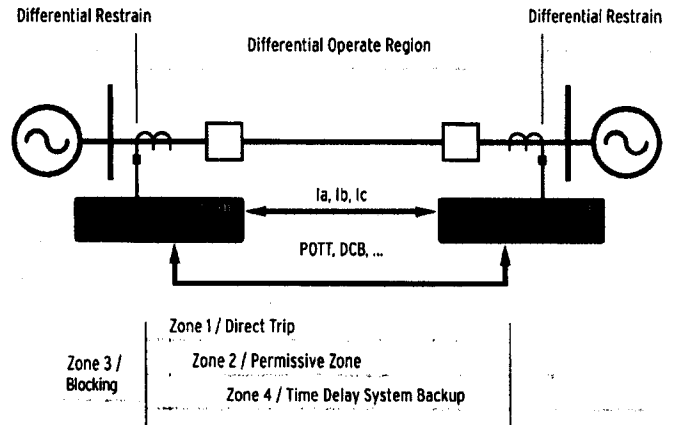

CT Characteristic Security

- Remain secure during external faults when CTs saturate at one or more terminals.
- Accommodate CT saturation, even in the first half cycle.
- Use existing CTs without ratio or characteristic matching.

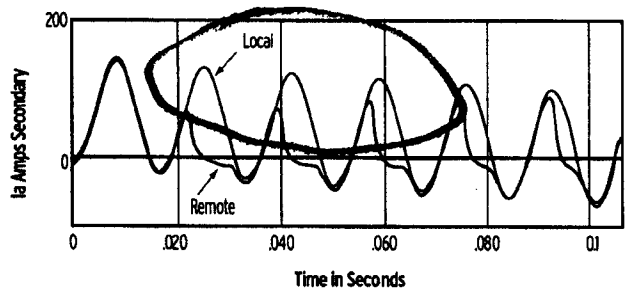

Flexible Channel Selection

- Select either single- or dual-channel operation using any combination of ITU-T G.703, EIA-422 (56 or 64 kbps), multimode fiber, or single-mode fiber.
- Use hot standby channel to increase dependability and security. Protection is not delayed and security is not compromised when the primary channel fails.
- Accommodate nonsymmetrical channel delays and channel-delay changes without desensitizing or delaying protection.

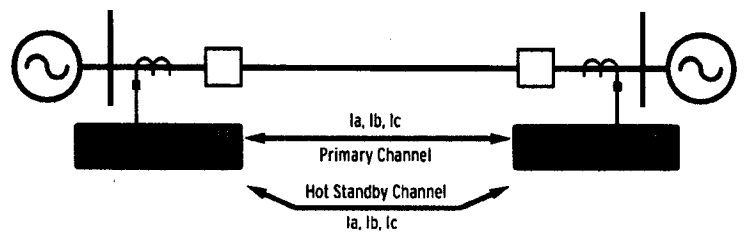

Tapped Line Coordination

- Use SEL-311L Relays on tapped lines without misoperation due to faults on the tap. Differential time-overcurrent elements calculate tap current to coordinate with tap protection.
- Choose between fuse-saving and trip-saving schemes for tapped loads. Use recloser shot count to select protection characteristic.

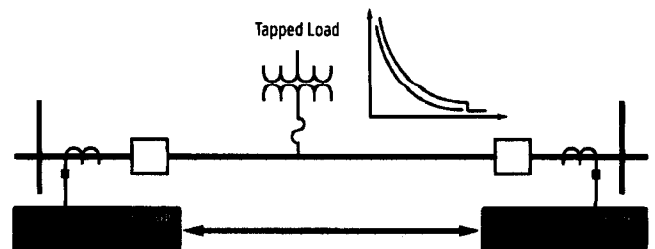

SEL-311L Line Current Differential Protection and Automation System

Three-Terminal Application

- Protect three-terminal lines with two or three channels. If three channels are used, the loss of any channel does not compromise protection.
- Provide high-speed operation for all terminals, even with weak infeed.
- Apply a third SEL-311L Relay at a tapped load, even without a breaker. Differential elements provide high-speed line operation without overtripping for faults on the tap.

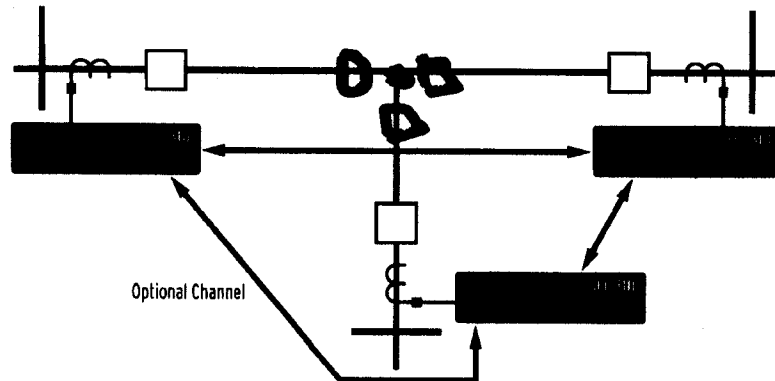

Wide-Area Measurements

Synchrophasor Measurements

View absolute phase angles from across the power system.

High-Accuracy Timing

Use precise timestamping to improve analysis of wide-area events.

**SYNCHROPHASOR
READY™**

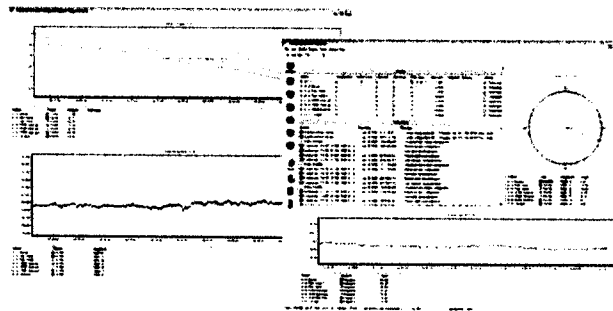

SYNCHROWAVE™

SYNCHROWAVE™ Software concentrates and displays data from across the power system.

General Specifications

Output Contacts (14 total)

6 High-Speed, High I/C Contacts

- Pickup time <math><200 \mu\text{s}</math>
- 6 A continuous
- 30 A make per IEEE C37.90-1989
- Break 10 A

8 Standard Contacts

- Pickup time <math><5 \text{ ms}</math>
- 6 A continuous
- 30 A make per IEEE C37.90-1989

Differential Ports

Any combination of one or two of the following:

- ITU-T G.703 codirectional at 64 kbps
- EIA-422 at 56/64 kbps
- 850 nm multimode fiber¹
- 1300 nm single-mode fiber¹

Operating Temperature

-40° to +85°C (-40° to +185°F)

Commitment to Quality

Schweitzer Engineering Laboratories, Inc. is committed to quality. Our certification to the ISO 9001 quality standard and our worldwide, ten-year product warranty are examples of this commitment. We encourage and appreciate your feedback about the use of SEL equipment, and we will use this information to continually improve our products and services.



© 2000, 2002, 2006 by Schweitzer Engineering Laboratories, Inc. All rights reserved. All brand or product names appearing in this document are the trademark or registered trademark of their respective holders. No SEL trademarks may be used without written permission. SEL products appearing in this document may be covered by US and foreign patents. PF00010 - 20060817

¹ Eye-safe, Class I laser product per EN 60825-1

SEL SCHWEITZER
ENGINEERING
LABORATORIES

2350 NE Hopkins Court • Pullman, WA 99163-5603 USA
Tel: 509.332.1890 • Fax: 509.332.7990 • Email: info@selinc.com
www.selinc.com • www.selindustrial.com

Making Electric Power Safer, More Reliable, and More Economical®