

Ongoing List of Topics:

- URL <https://pages.mtu.edu/~bamork/EE5223/index.htm>
- Term Project - last few proj/teams being firmed up and getting moving.
 - Follow timeline, see posting on web page
 - This Friday - develop formal outline w/complete reference list
- Protection fundamentals (cont'd):
 - Distance relaying fundamentals (cont'd): §6.5.6, §6.5.7
 - Observed vs actual Z: Three-terminal lines, series caps
 - Next: Transformer protection (Chapter 9)
 - Differential relay for internal fault protection
 - Other monitoring and protection systems
 - Again — overview of bus diff, xfmr diff, synch check, capacitor banks, generators, motors, etc. (take a quick run through Ch.6, also Glover & Sarma, Ch.10).

-
- Protection fundamentals in preparation for next EE5224 relaying lab:
 - Gen diff 87G - quite simple, connect CTs so current flows in “do-nothing” loop through Restraint elements (resulting in near-zero current through Operate element). Use equal (preferably full) ratio with all CTs. Differential slope of trip characteristic is rather flat compared to 87T below. Example shown of how not to connect CT secondaries.
 - Xfmr diff 87T - a) must connect CT secondaries to provide proper phase shift so that restraint currents flowing through restraint elements are in phase; b) relay settings are used to compensate for pri voltage ratio and CT ratios. CT accuracy problems can be a big concern due to having to use less than full CT ratio, and having Pri and Sec CTs with different accuracy levels. Differential slope of trip characteristic can be 10%, 15%, 25% to allow for mismatch (measurement error) due to CT accuracy problems.

Impedance Relaying - (21)

"distance relaying"

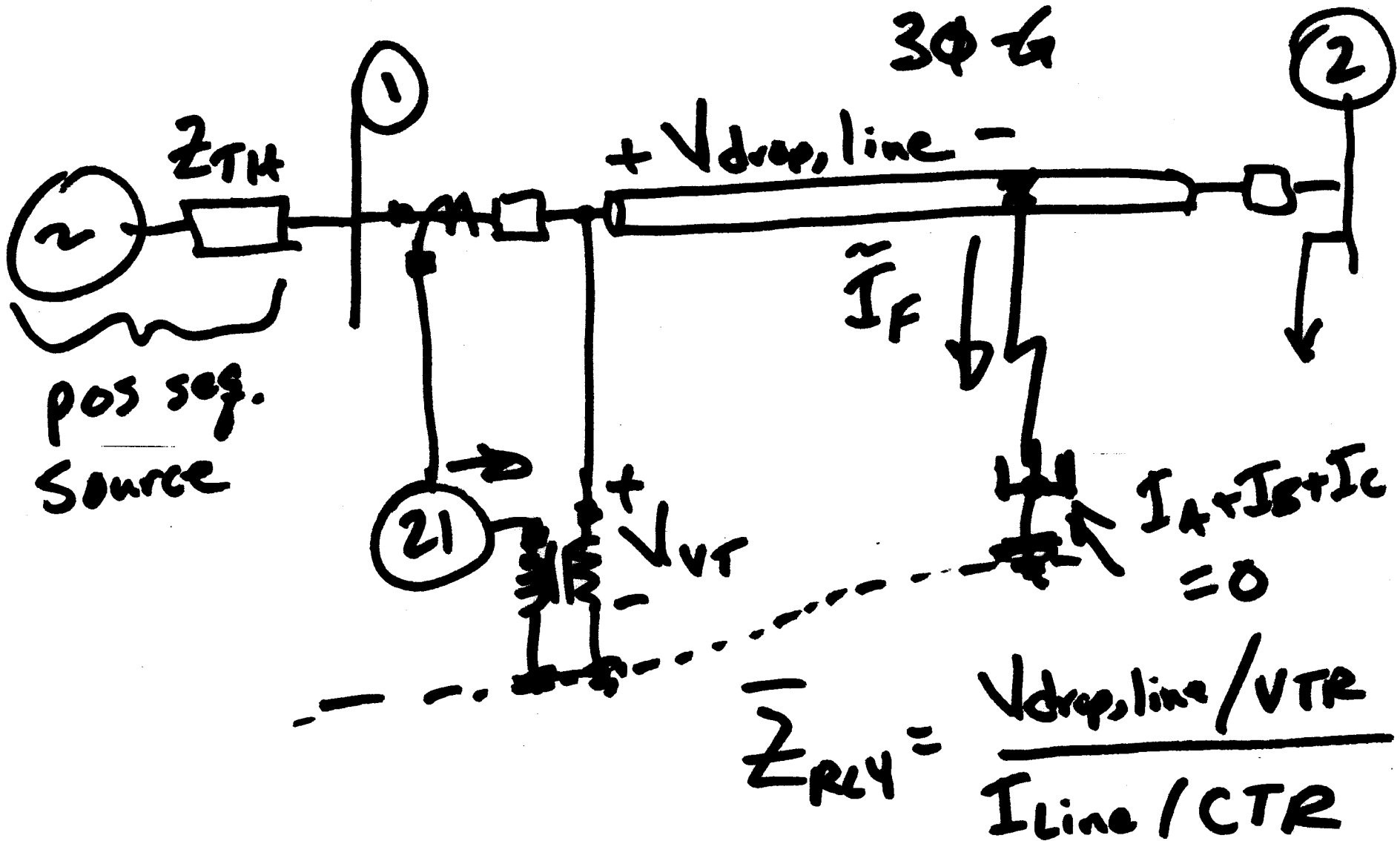

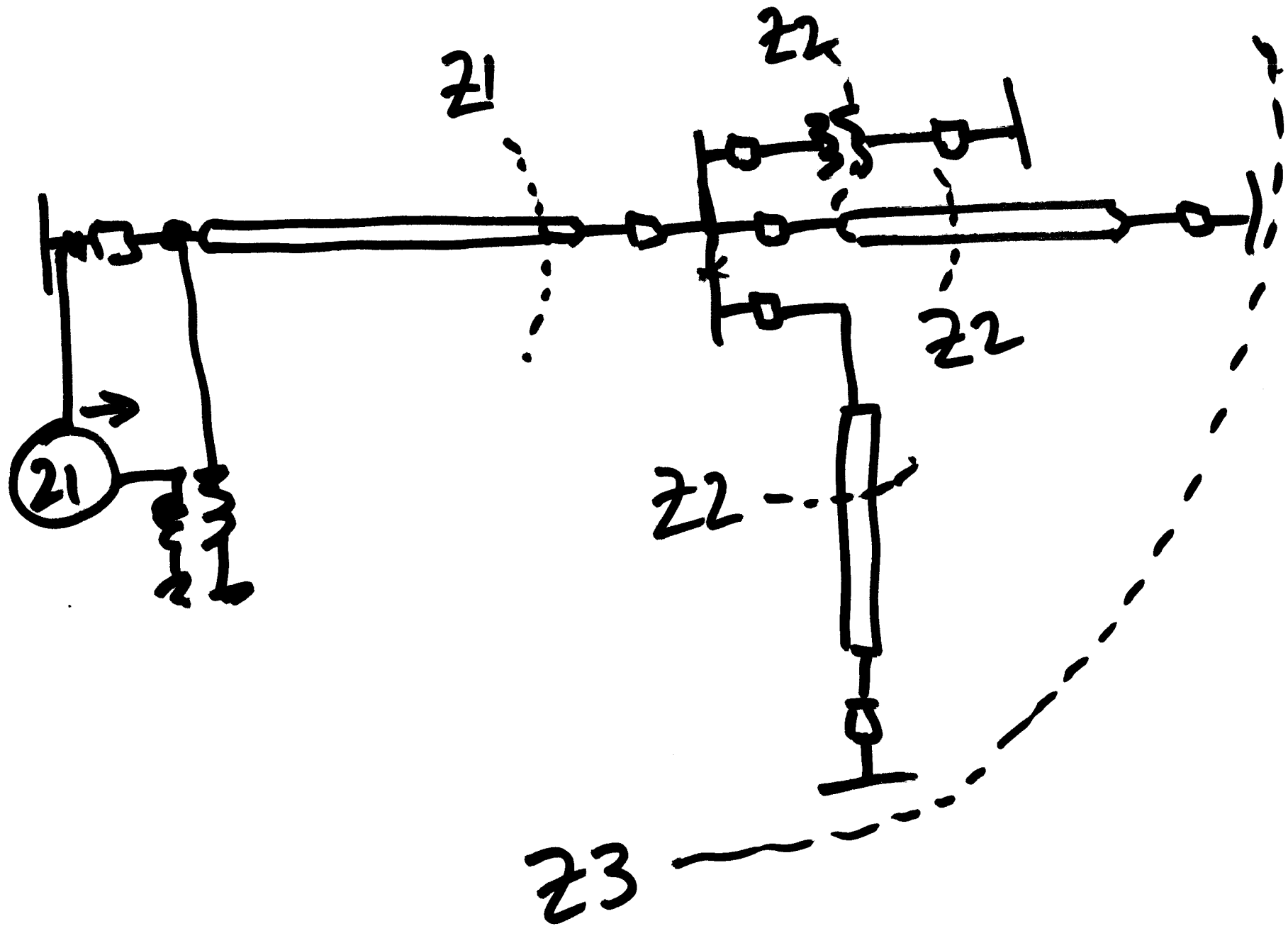
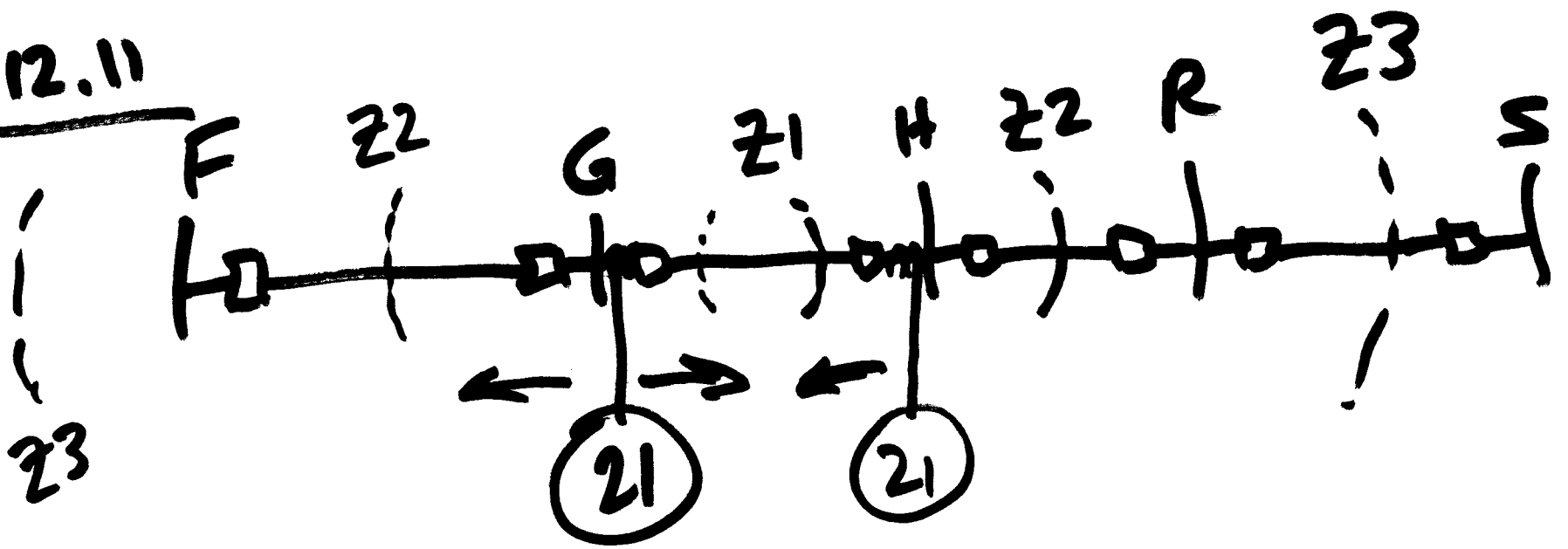

Fig 12.11



Line Protection

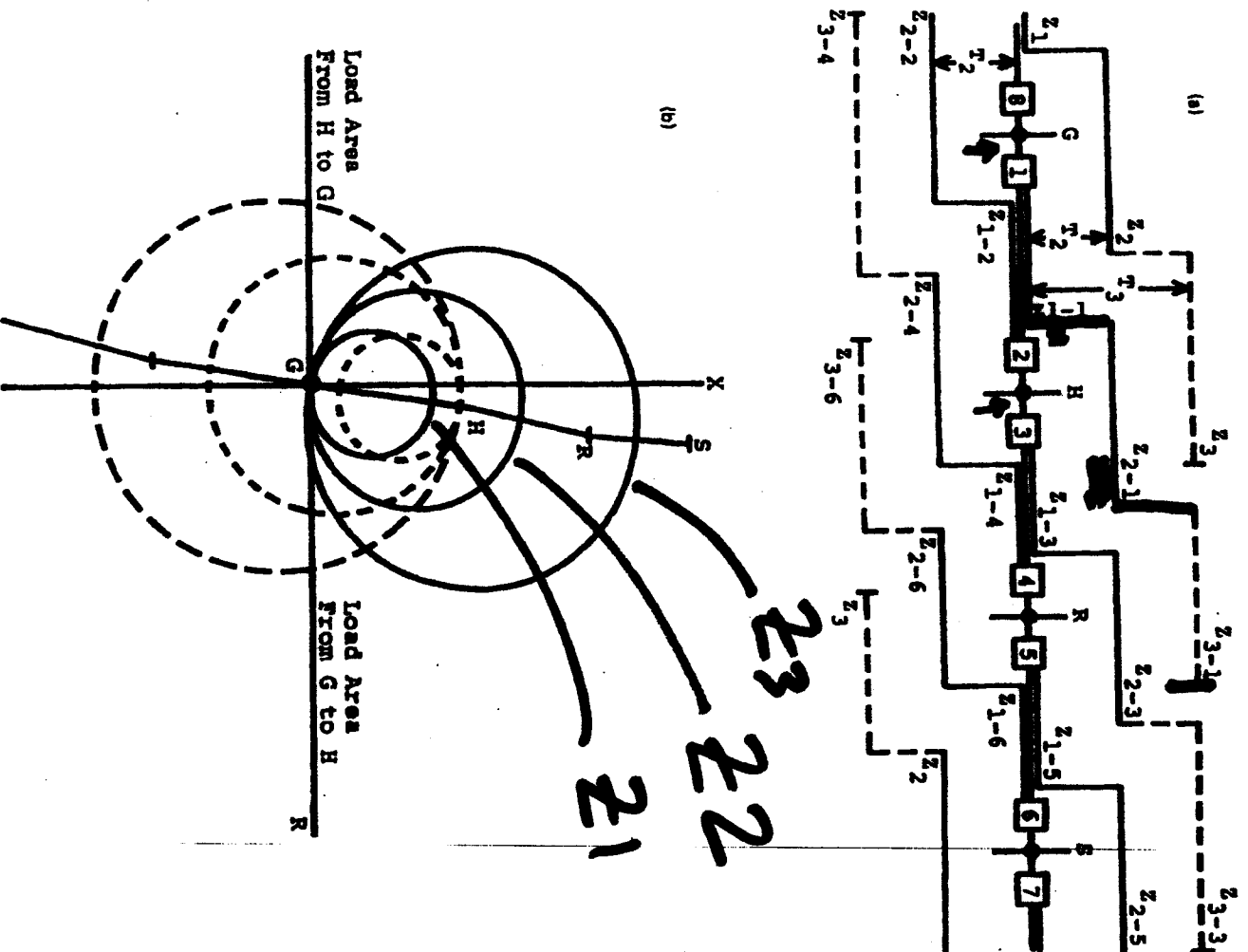
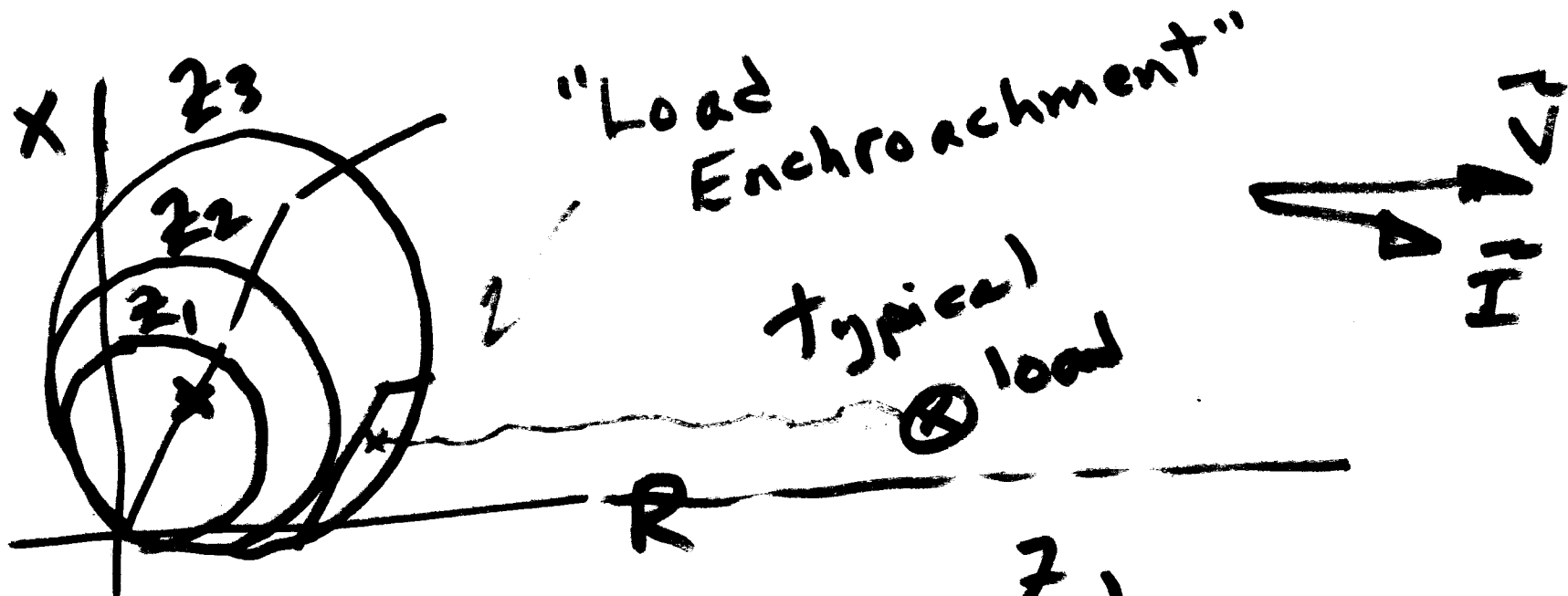
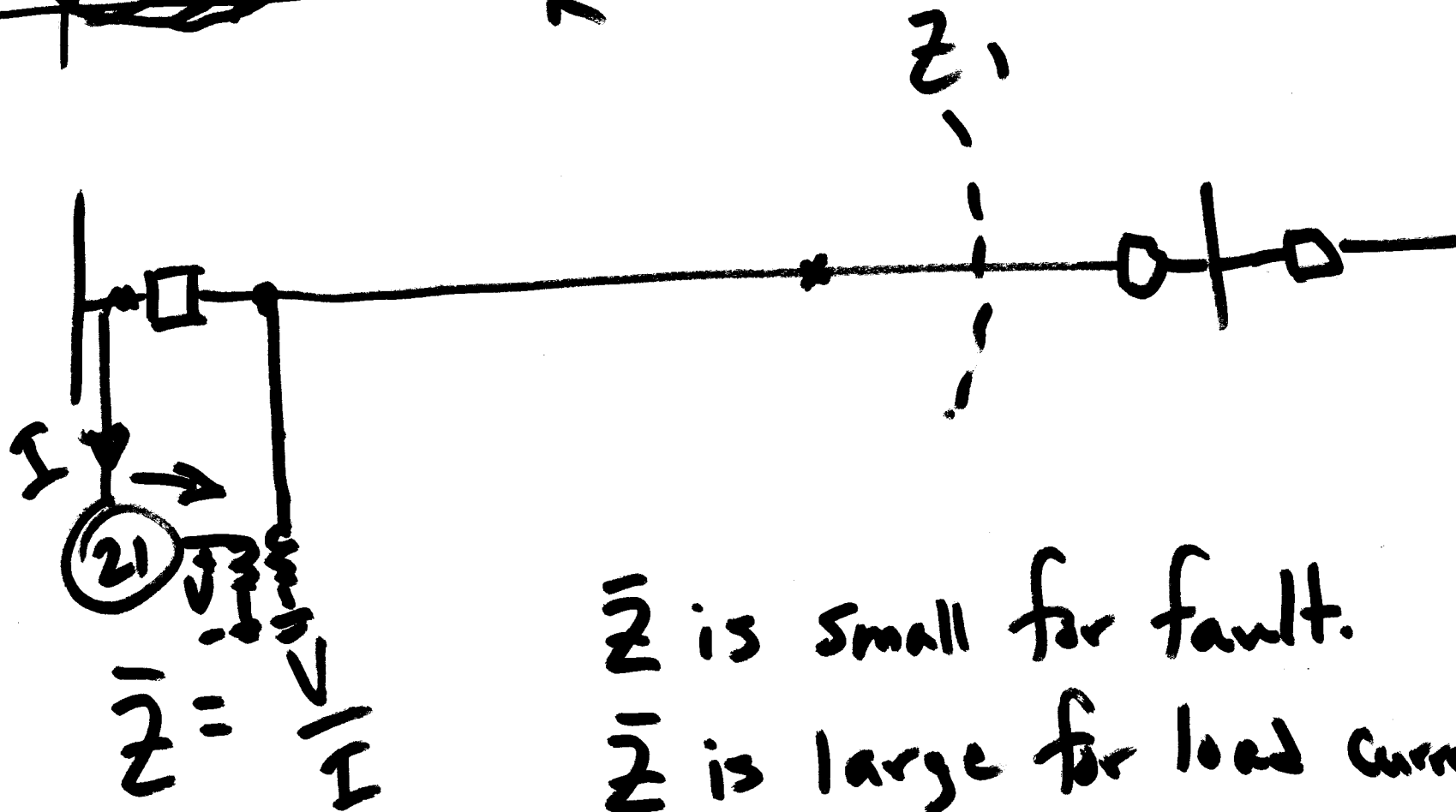
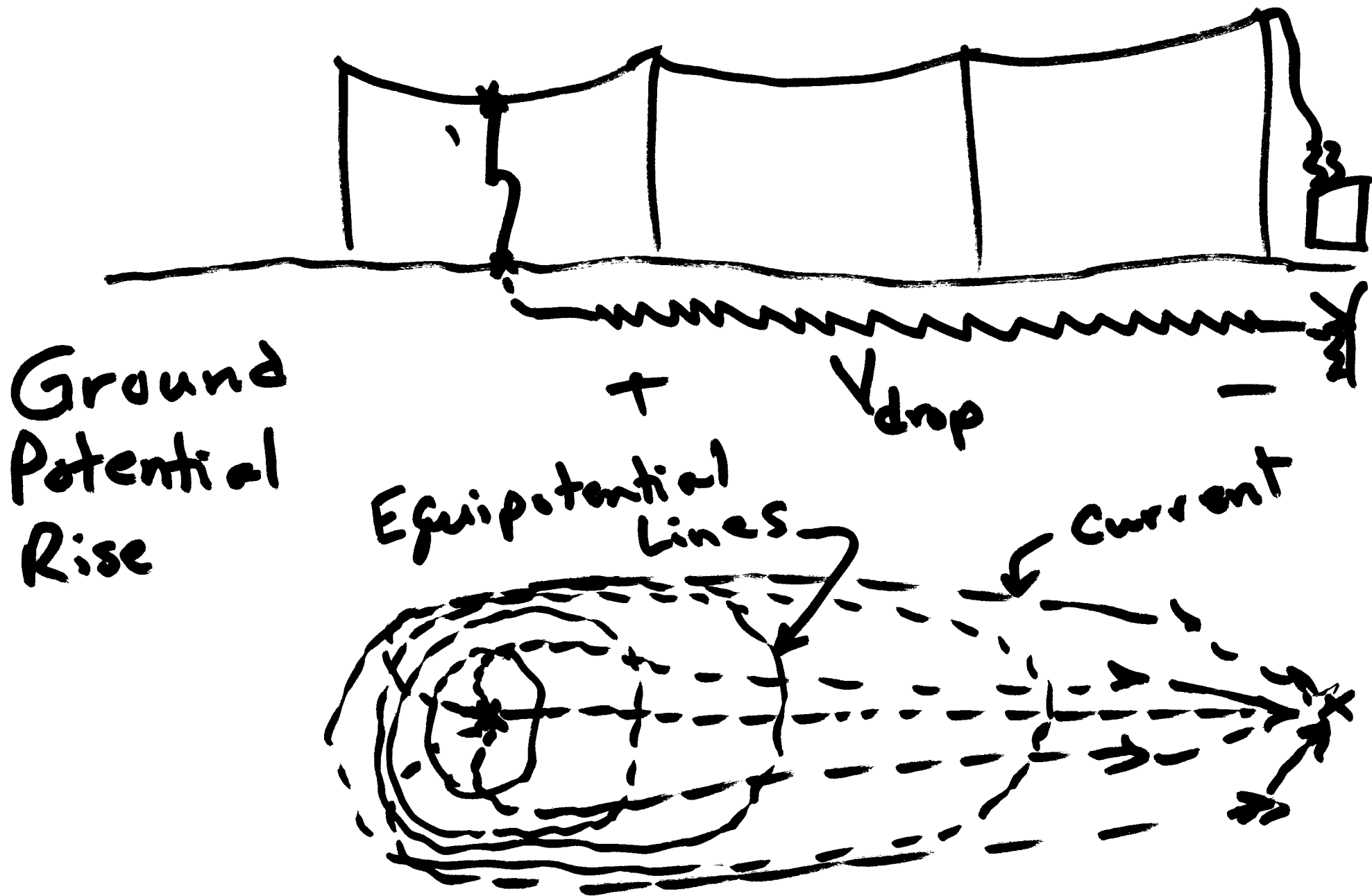

Figure 12.11 Protection zones with distance relays: (a) time--distance plot; (b) R-X diagram plot.



⊗





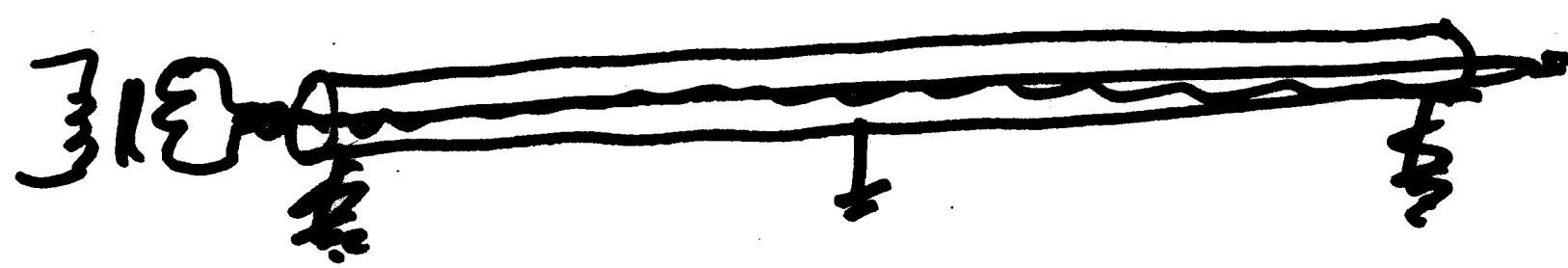

- Drainage Reactors
- Isolation & fuses
- Surge Arresters

Leased Lines
 $\leq 300V$

Sub A

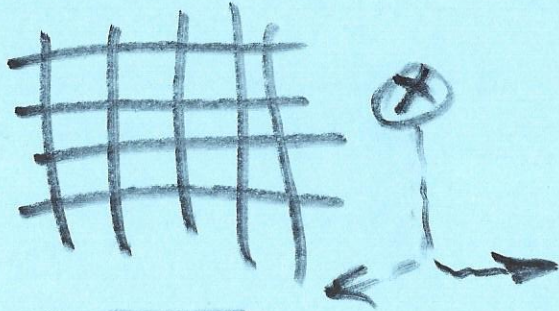

Sub B

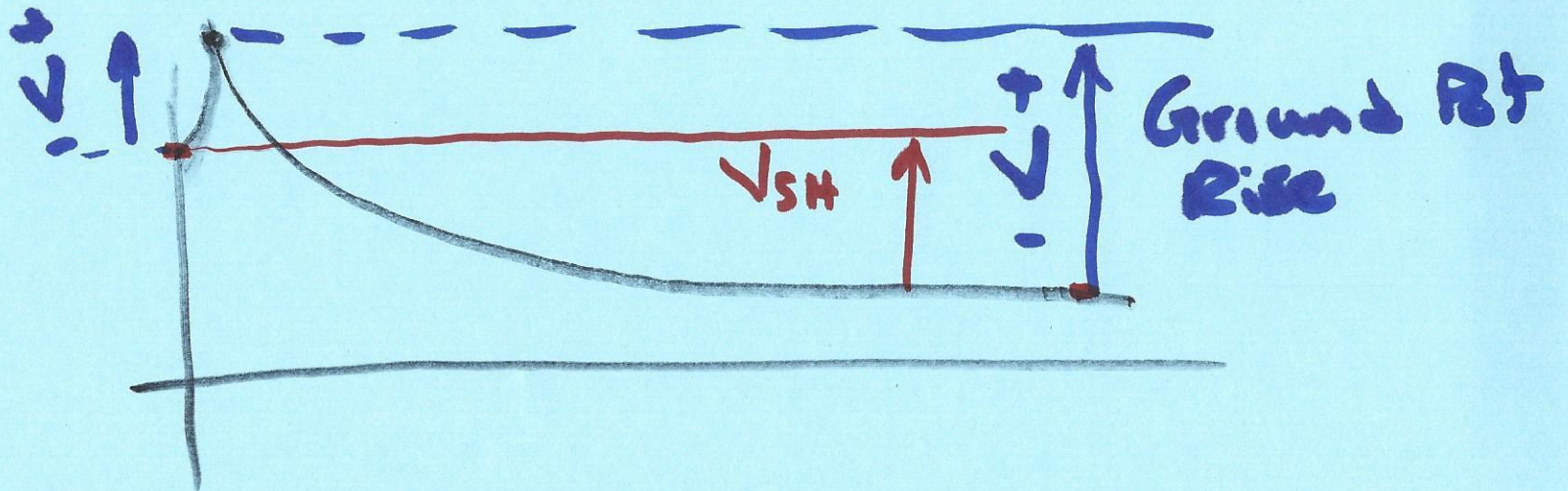
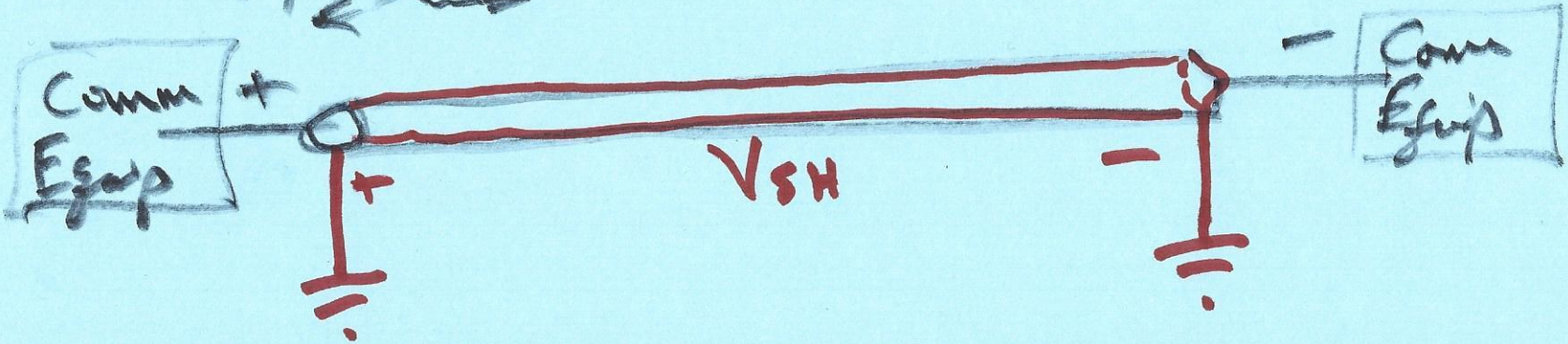
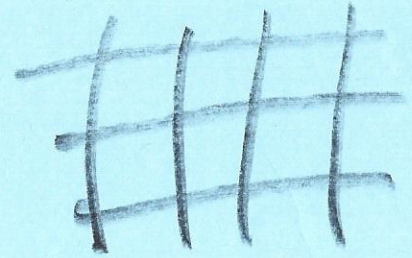

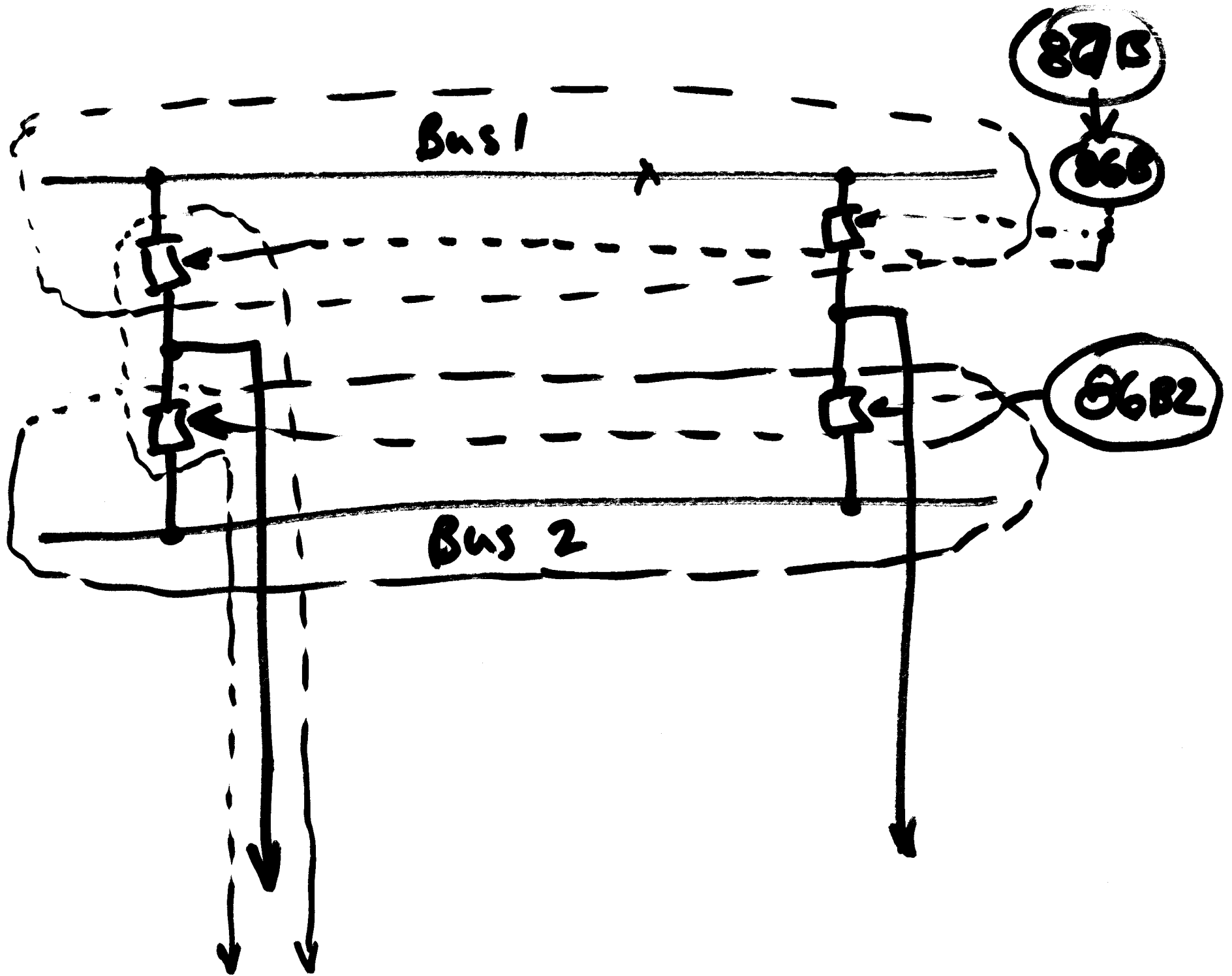

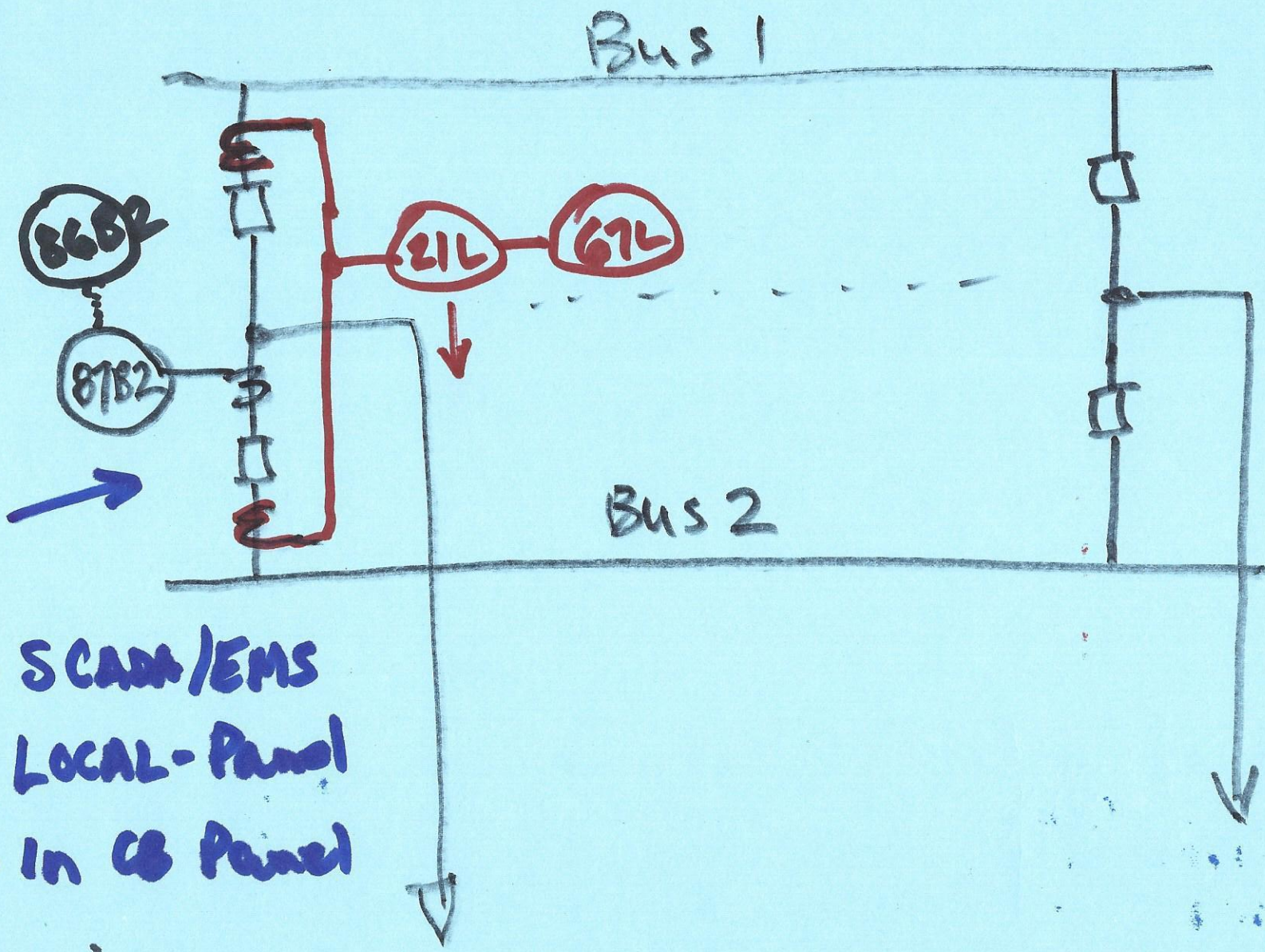

- SCADA/EMS
- LOCAL-Panel
- In CB Panel

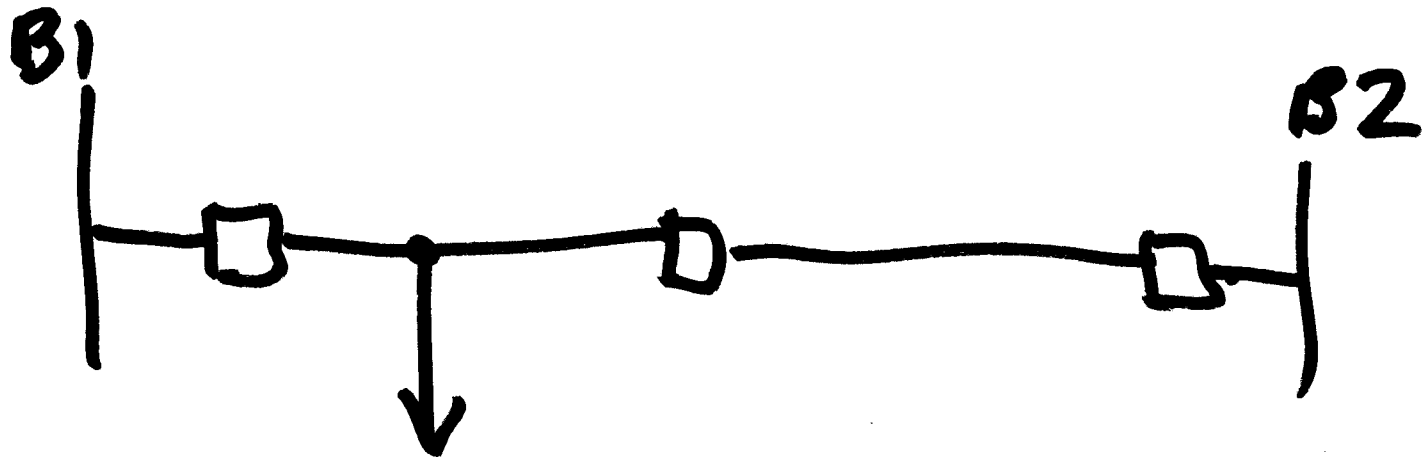
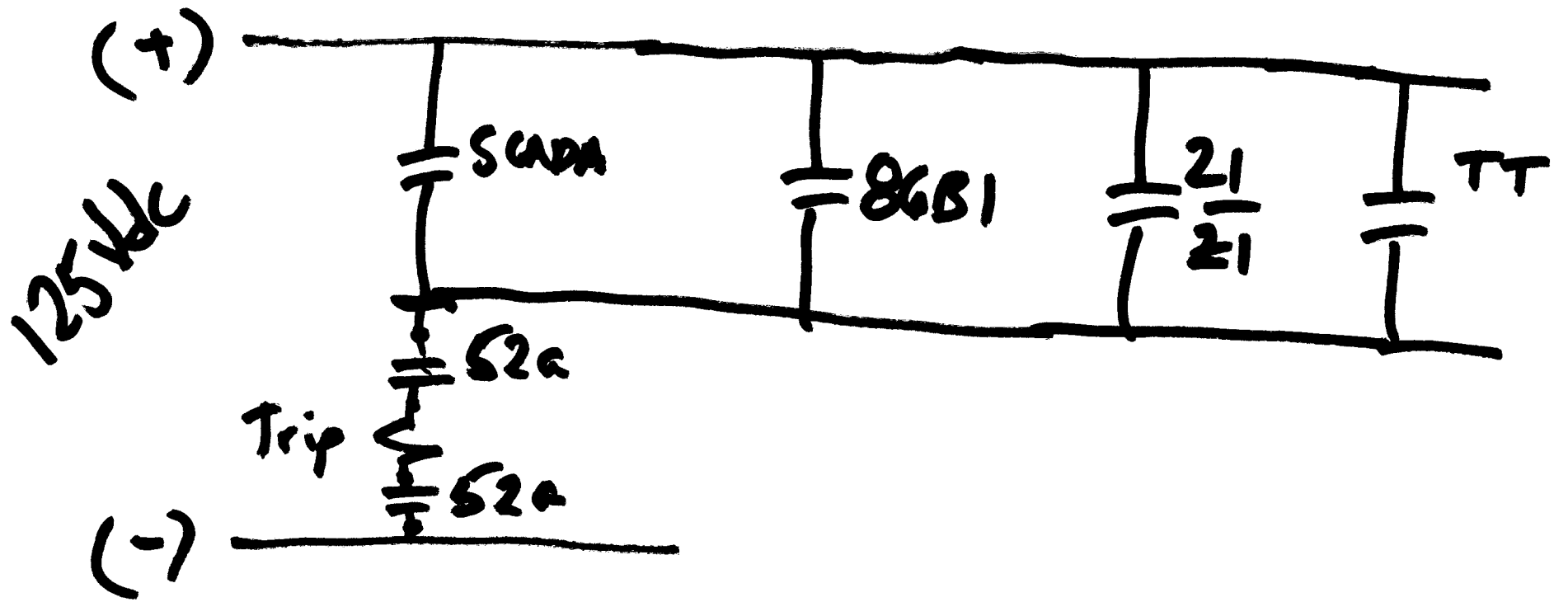

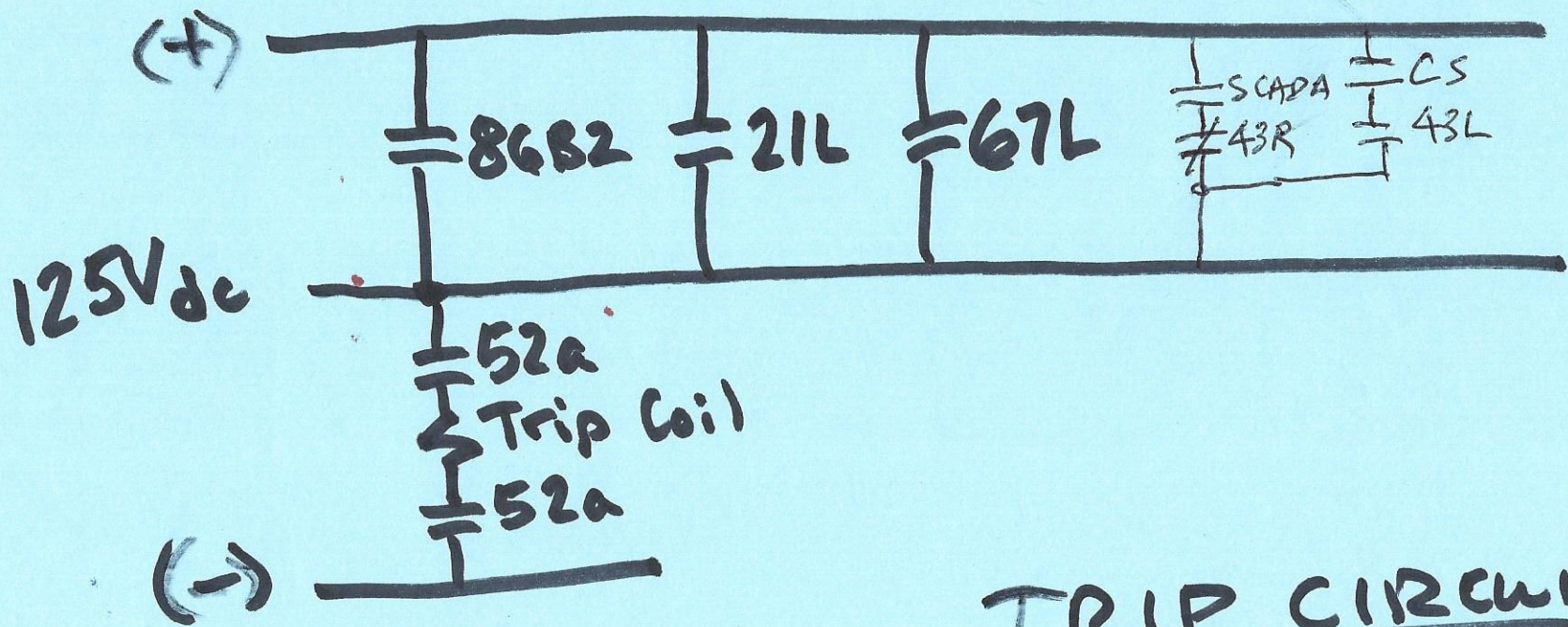

TRIP CIRCUIT

CB 2032

(range 85–95%) of the positive-sequence line impedance, zone 2 approximately 50% into the next adjacent line, and zone 3 approximately 25% into the adjacent line beyond. Where possible, zones 2 and 3 provide backup for all the adjacent lines at operating times of T_2 and T_3 .

Figure 12.11b shows the operating circles for the three zones at bus G, breaker 1 (solid line) and at bus H, breaker 2 (broken line), plotted on the $R-X$ diagram. The several lines are shown at their respective $r + jx$ positions. The relays operate when the ratio of fault voltage to current falls within the circles. Load impedance (see Equation 6.2) normally falls in the general areas shown.

On long lines, where large mho operating circles can include the load areas, the restrictive characteristics illustrated in Figure 6.13c, Figure 6.13d, or Figure 6.13e are used. They provide a long reach in the fault area, with quite a restricted reach in the load areas.

The operating circles must be set such that they do not operate on any system swings from which the system can recover. Such swings occur after a system disturbance, such as faults, sudden loss of generation or load, or from switching operations. This is discussed later. These swings may also require application of the restricted operating characteristics.

Zone 1 at each end of the line provides the most desirable protection—simultaneous high-speed operation for the middle 80% of the line section. This can be increased to 100% only with pilot relaying.

Backup protection, as suggested in Figure 12.11, is ideal and seldom obtainable. In practice, most buses have multiple lines of different lengths and with power sources at their remote ends. A typical example is illustrated in Figure 12.12. The relays at breaker 1, bus G protecting line GH look into lines HR and HS extending from bus H. Where line HR is short and line HS is long, zone 2 set for 50% of line HR will cover only a small percentage of line HS. Setting for 50% of line HS would result in possibly overreaching and miscoordinating with Z_2 of line HR, unless T_2 time was increased. This problem is multiplied with other lines of different lengths extending from bus H. However, the reach will not be as far as indicated because of the “infeed

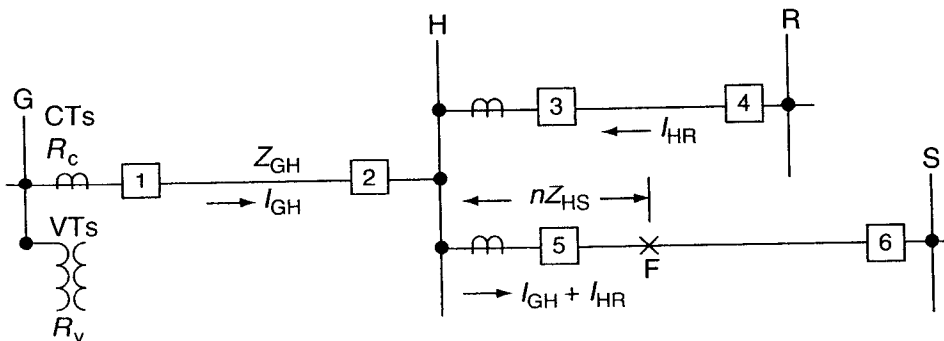

FIGURE 12.12 Protection for multiple lines and infeed at a remote bus.

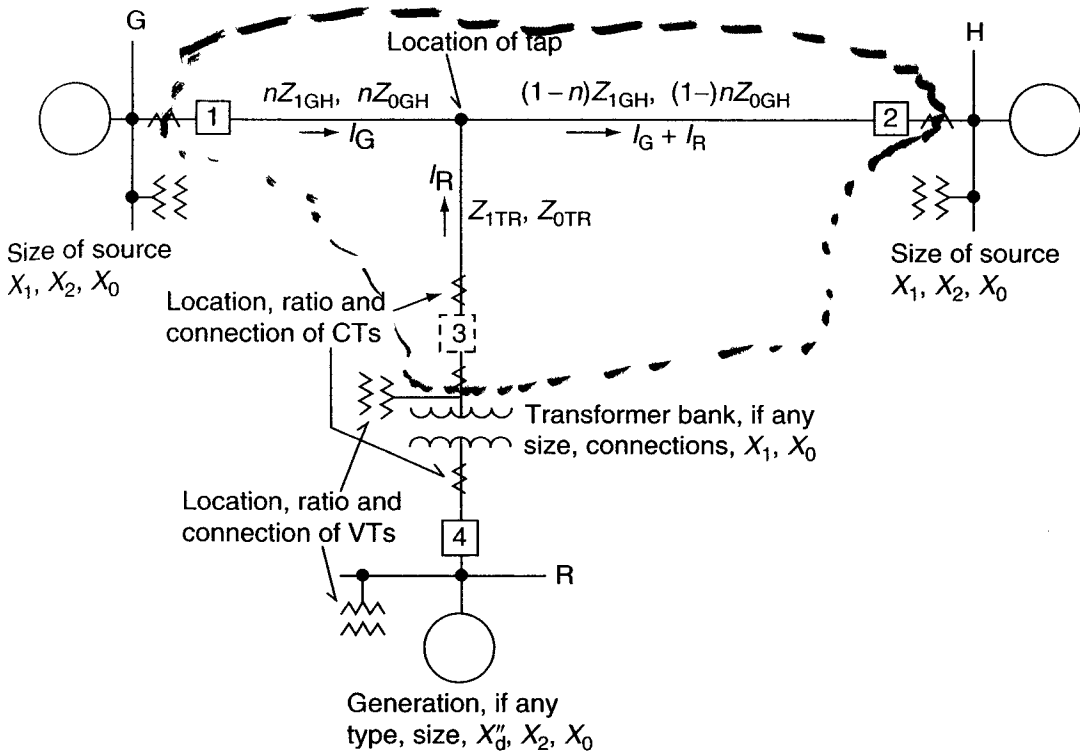

FIGURE 12.13 Typical tapped line and information required for a protection study. Currents are for a fault at bus H.

protection, considerable information is required, such as the type of tap(s) (see Figure 12.13 or Figure 12.14). If the taps are of the Figure 12.13 type, then beyond the normal information for the two-terminal lines, the information outlined on the figure should be supplied or obtained. If a wye-delta transformer bank is included as part of the tap, information that shows how the bank is grounded is required. Amazingly, this information is very frequently omitted from station one-line diagrams.

Consider the line of Figure 12.13; the tap T may be a transformer at or near the line, so that Z_{TR} would be the sum of the impedance from the tap and the transformer bank impedance. Sometimes, the tap ties through Z_{TR} to a bus, as shown in the figure. The tap may serve a load, so that negligible fault

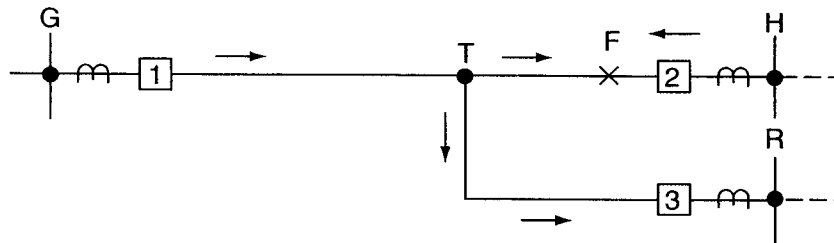
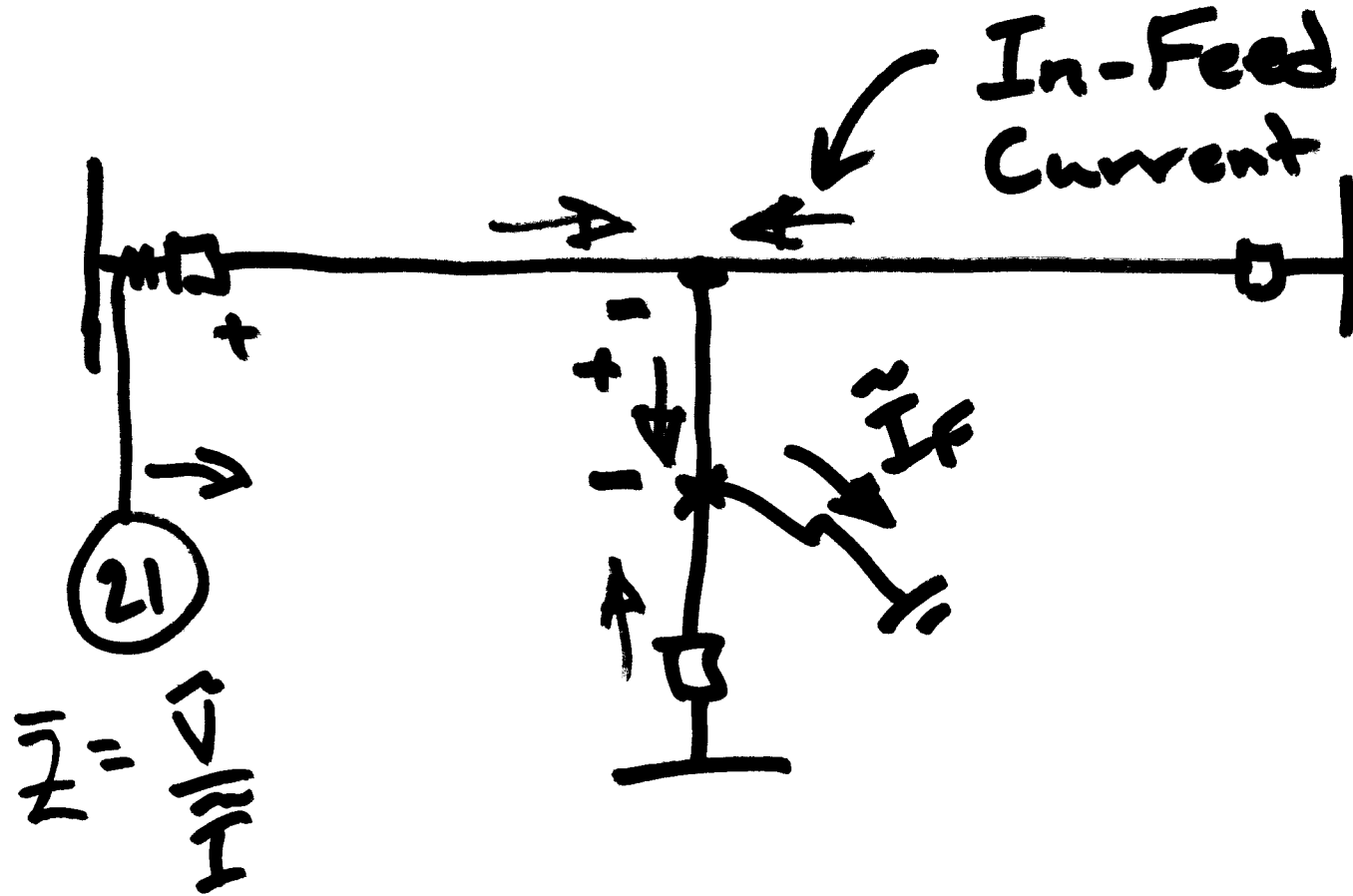
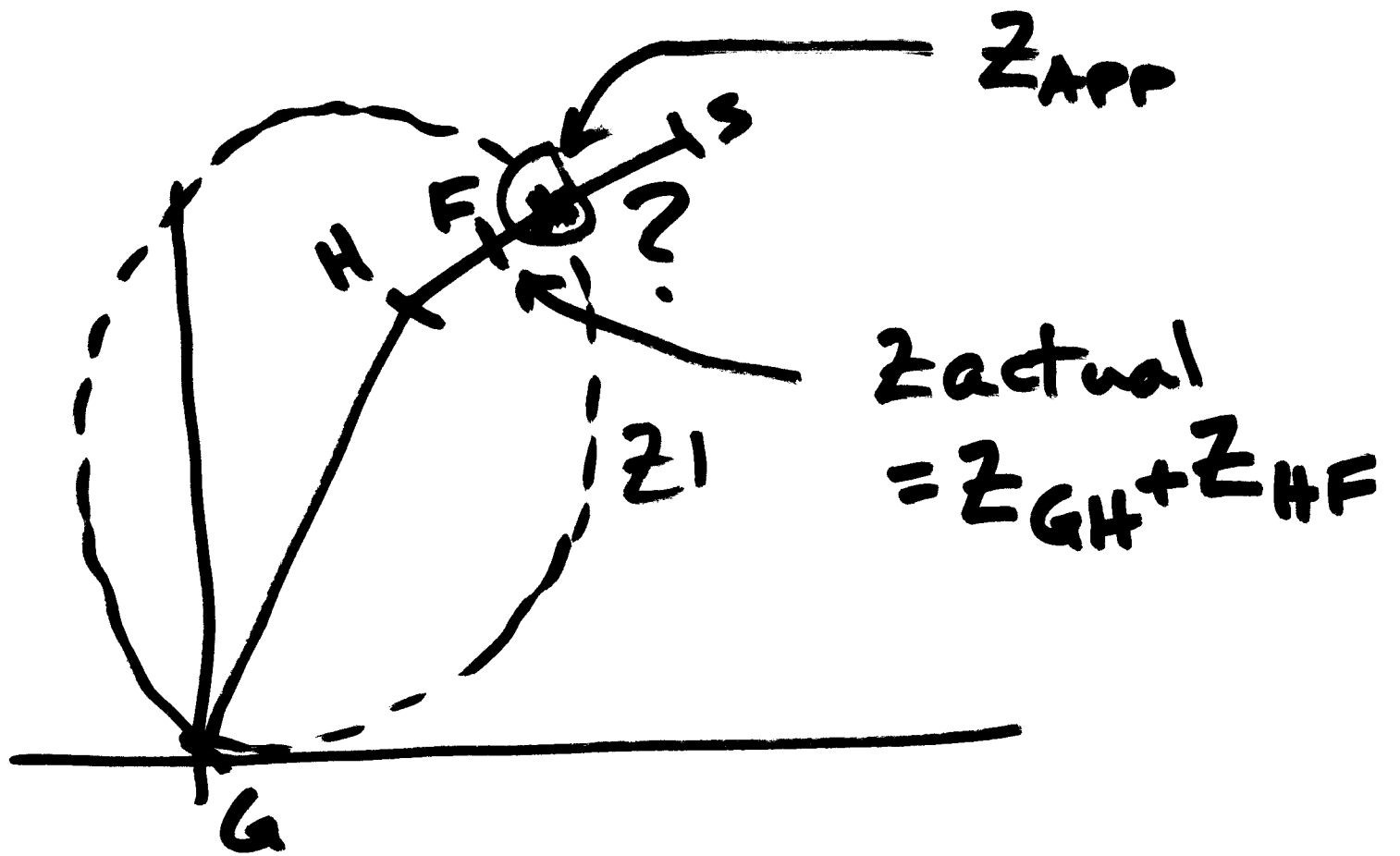
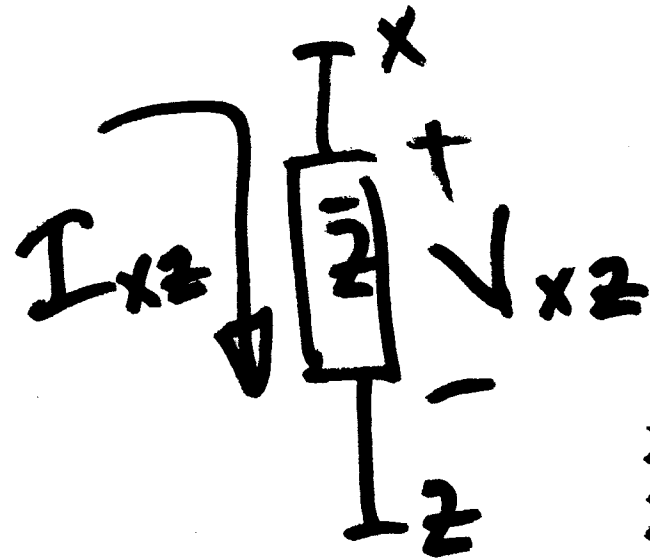

FIGURE 12.14 Multiterminal line where fault current can flow out at one terminal for internal faults.





$$Z_{actual} = Z_{GH} + Z_{HF}$$



$$\bar{z}_{x2} = \frac{\bar{V}_{x2}}{\bar{I}_{x2}} = -\frac{\bar{V}_{2x}}{\bar{I}_{x2}}$$

passive

Three-Terminal Lines

Fig. 12.12 943

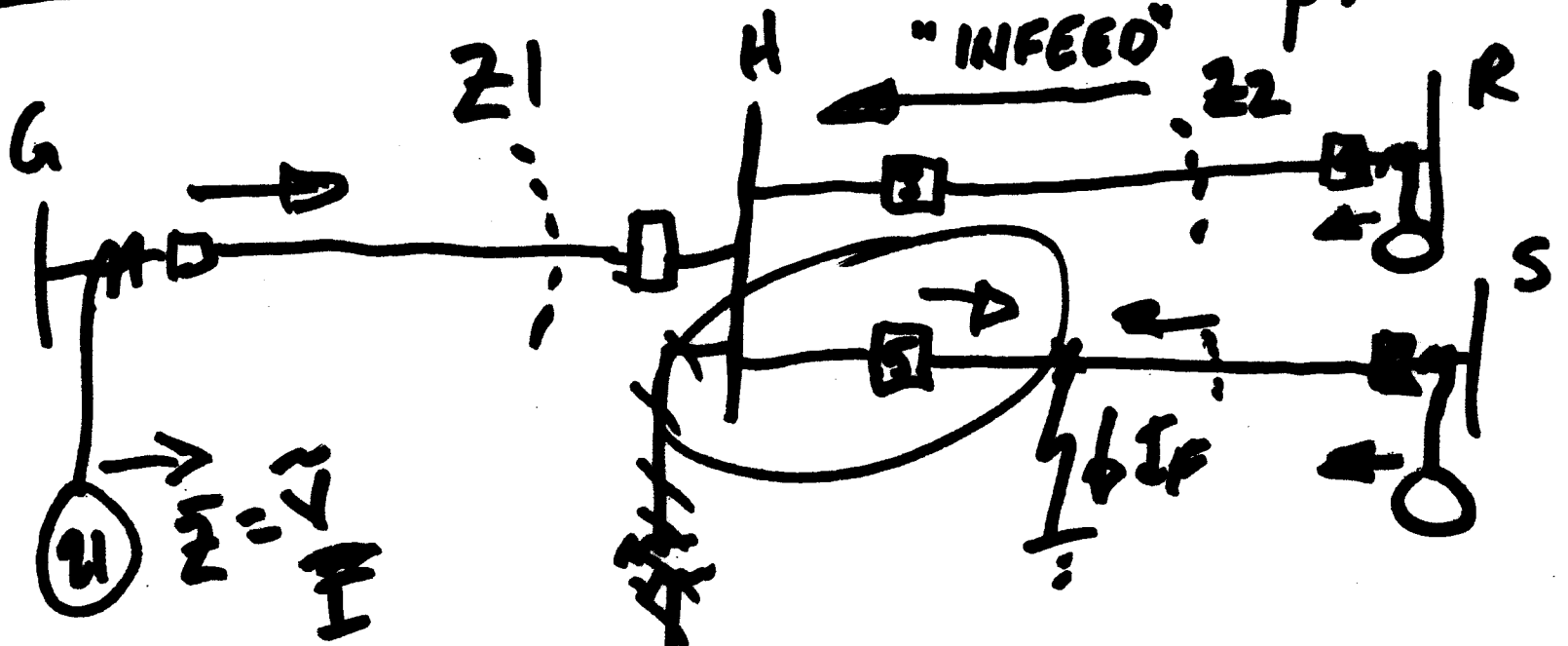

INFEED

- 3-Term
- zone 2, zone 3

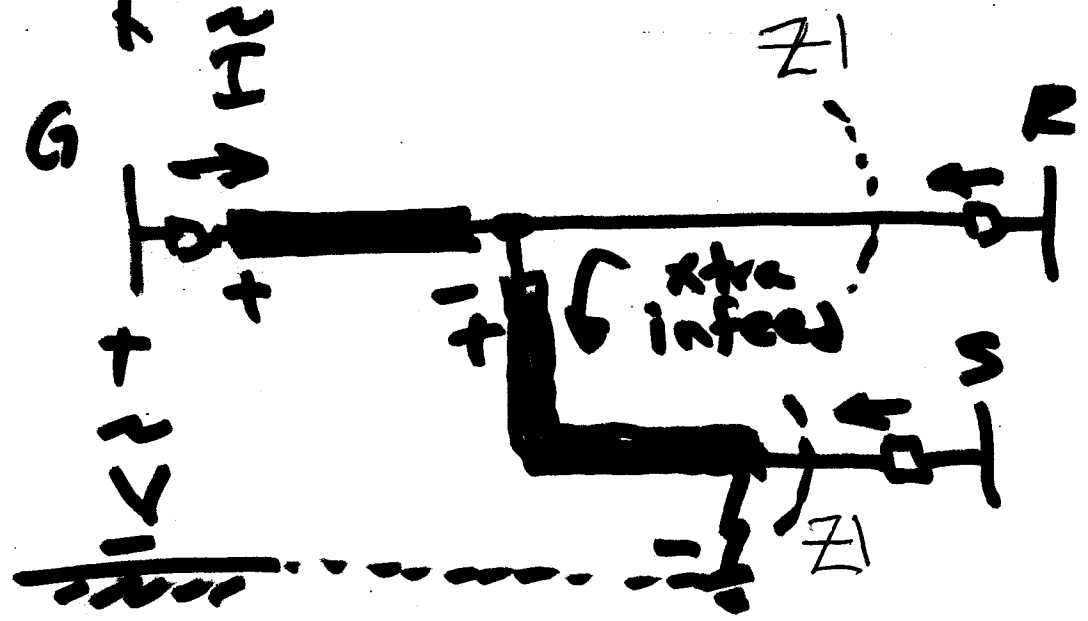

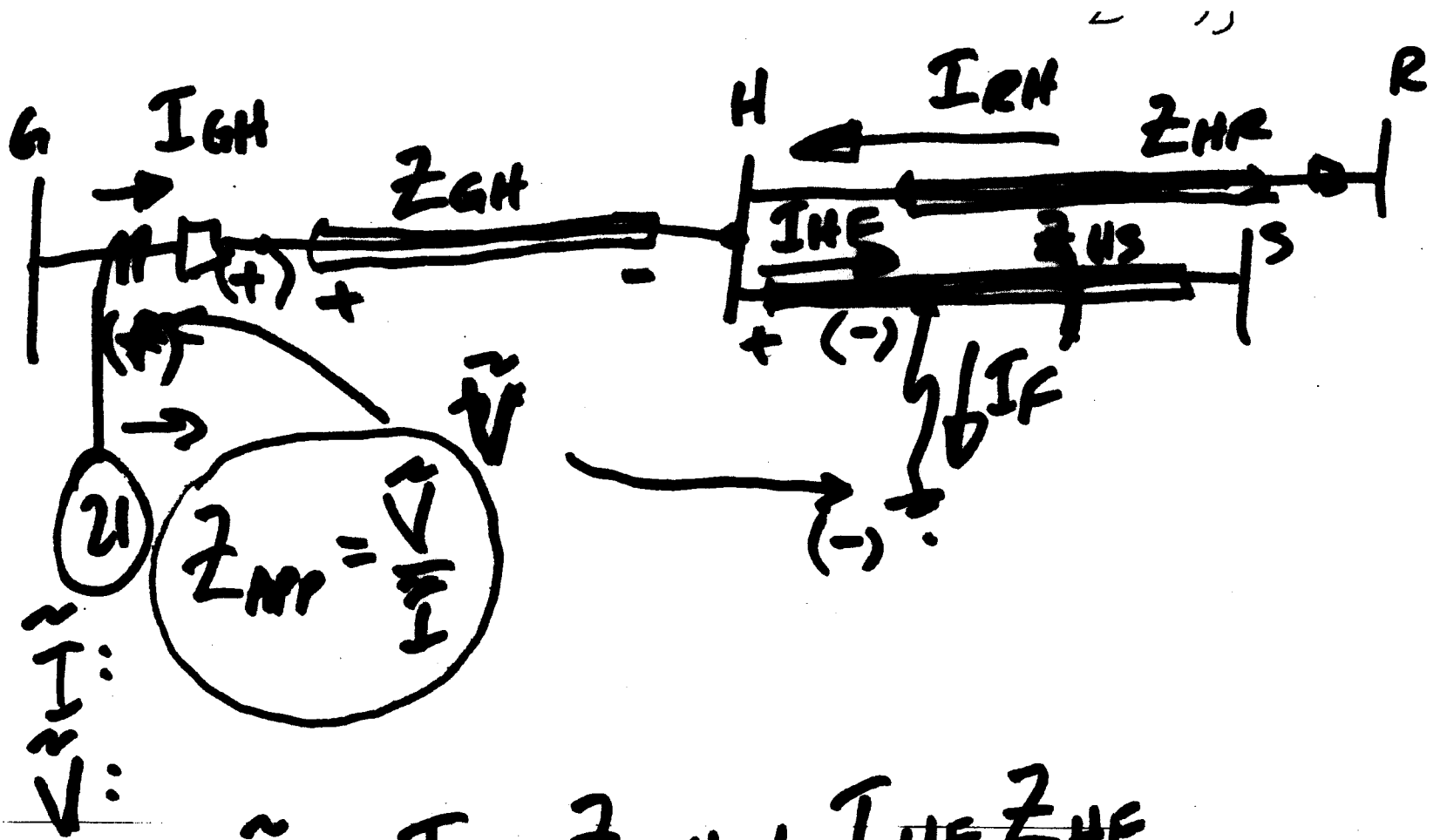

$$\begin{aligned}
 \tilde{V} &= I_{GH} Z_{GH} + I_{HF} Z_{HF} \\
 &= I_{GH} Z_{GH} + (I_{GH} + I_{RH}) Z_{HF} \\
 \tilde{V} &= \underbrace{I_{GH}}_{\text{Relay}} \underbrace{(Z_{GH} + Z_{HF})}_{\text{Actual } Z} + \underbrace{I_{RH} Z_{HF}}_{\text{Add'l } V \text{ due to infeed.}}
 \end{aligned}$$

$$\tilde{Z}_{APP} = \frac{\tilde{V}}{\tilde{I}_{GH}} = Z_{GH} + Z_{HF} + \underbrace{\frac{I_{RH} Z_{HF}}{I_{GH}}}_{\text{Voltage drop is more due to in-feed. Apparent } \tilde{Z} \text{ bigger than actual.}}$$

- Underreach: Reach of relay is less than setting.

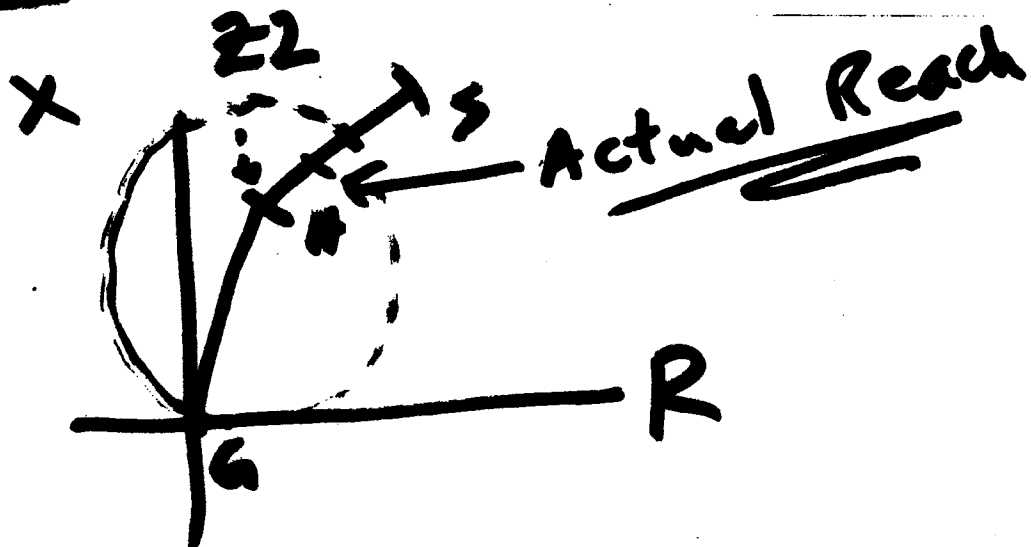

System Stability

OOS Prot.

Fault: fast
Swing: slow
S.S. Load

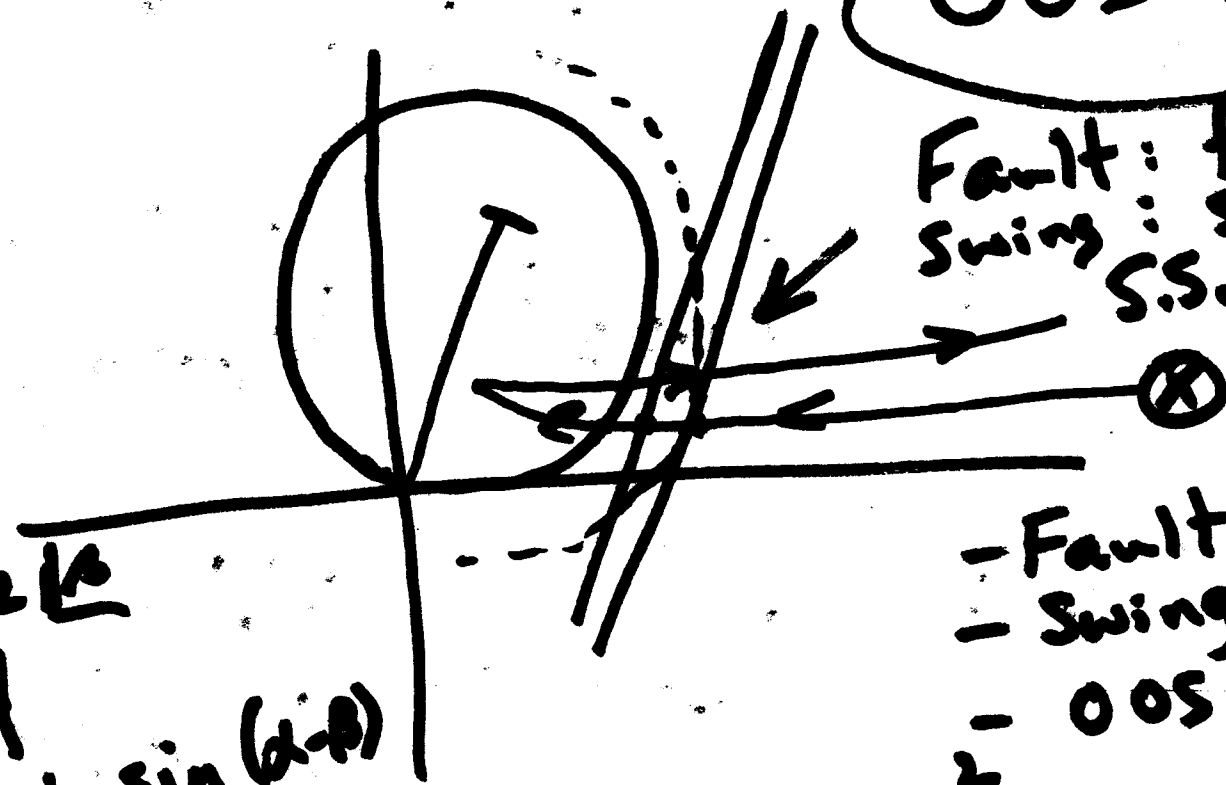

$V_1 \angle \alpha$ X_L $V_2 \angle \beta$

$$P_{1 \rightarrow 2} = \frac{V_1 V_2}{X_L} \sin(\alpha - \beta)$$

- Fault? - Trip
- Swing? - No Trip.
- OOS? - Trip

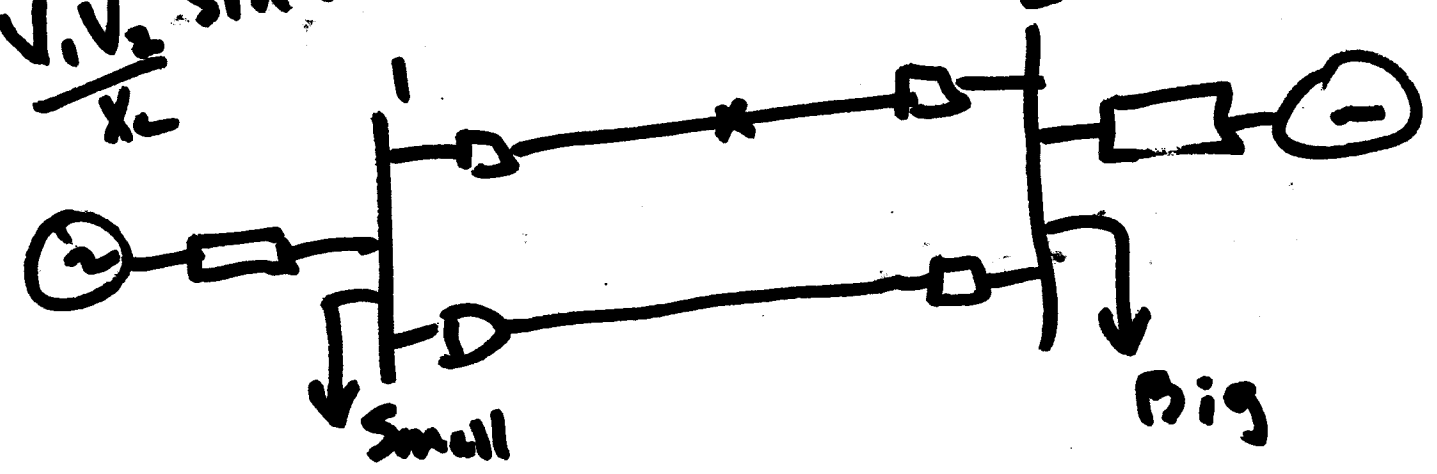

Some great insights from an expert...

From: "Tom Ernst (MP)" <TERNST@mnpower.com>

To: "(ee5223-l@mtu.edu)" <ee5223-l@mtu.edu>

Subject: Series Compensated Lines

Date: Mon, 28 Feb 2005 14:14:07 -0600

In the example in Friday's class (lecture 21) that Dr Mork drew, the net line impedance never goes capacitive (the $+jXL/2$ of each half of the line is larger than the $-jXC$ of the series capacitor). This is only possible if the compensation is less than 50%. Under these conditions, all you really need to do is set the zone 1 element based on the compensated line impedance (85% of $R + j(XL - XC)$ for example) and set the zone 2 based on the uncompensated line impedance (125% of $R + jXL$ for example). The main problem that the series capacitor causes is when the relay attempts to measure the miles to the fault based on a line model of ohms/mile. Faults on the C1 side of the capacitor appear to be further away than faults on the C2 side.

If the compensation is more than 50% or if the series capacitor is located close to one end, then the net fault impedance can go $-jX$ for faults on the far side of the cap bank. This can create problems with standard impedance relays misinterpreting the fault as being reverse. We need to use relays that are specially designed to deal with series compensated lines (each manufacturer approaches the problem differently) and, in some cases, we may have to wait for the capacitor to bypass before the element will operate reliably.

The other concern is the relay's performance during the transient conditions that exist while the series cap is in the process of bypassing. The arrester is a non-linear resistor so a parallel RC network is established with "ringing" characteristics which may cause the relay to operate slowly or incorrectly while the cap is bypassing.