

EE5223 Final Project Report

line to line distance relay protection analysis with GPS coordinated

Yawei Wei;Zhe Qin;Justin Sliva

Table of Content

1.	Introduction.....	6
2.	Background.....	6
2.1.	Power system phasor definition	6
2.2.	Synchrophasor definition and measurements.....	7
2.3.	SEL421 relay connection.....	7
2.4.	SEL311L relay settings	9
2.5.	GPS clock connection.....	9
2.6.	SEL 3351 system computing platform.....	10
2.7.	Doble Power System Simulator	10
3.	Proposed Approach	11
3.1.	Relay Testing Power System Modeling Build	11
3.2.	Relay Fault Behavior Testing with ASPEN software.....	12
3.3.	Relay Testing with Doble F6150A and ATP	12
4.	Result	13
4.1.	ASPEN Simulation Result	13
4.2.	Experiments Result	16
4.2.1.	Relay fault with GPS coordinated.....	17
4.2.2.	Relay trip result comparison	18
5.	Recommendation of future work	19
5.1.	Improve system scale to test the performance	19
5.2.	Analysis relay Zone-3 protection with GPS coordinated.....	19
	State of contribution.....	20
	Reference	20
	Appendix.....	23

List of Figures

Figure 1: Relay with GPS coordinated	6
Figure 2: SEL421 High-Speed line Protection, Automation, and Control System.....	7
Figure 3: SEL421 relay function box	8
Figure 4: Diagram of How the Synchrophasor Processes Data	9
Figure 5: SEL311L line current differential protection	9
Figure 6: SEL2407 GPS Clock	10
Figure 7: SEL system computing platform.....	10
Figure 8: Doble F6150A power simulator	10
Figure 9: Power protection testing model	11
Figure 10: Simply model for software simulation	12
Figure 11: Aspen simulation.....	12
Figure 12: Atp model for simulation	12
Figure 13: Aspen result for distance protection.....	13
Figure 14: Result of Line to line middle fault	13
Figure 15: Aspen result of line to ground fault	14
Figure 21: Doble Macro Settings	
Figure 22: Relay GPS coordinated information	17
Figure 23: Relay Event for tripping analysis	17
Figure 24: Relay with line to line fault comparison.....	18
Figure 25: Relay with 3-phase fault comparison.....	18
Figure 26: multi-PMU system configuration	19
Figure 27: Zone 3 protection with PMU devices.....	19
Figure 28: SEL 421 with GPS connection.....	24
Figure 29: GPS testing	24
Figure 30: High-Accuracy Timekeeping Connections.....	25
Figure 31: SEL421 Distance relay setting.....	25

List of Tables

Table 1: 230kV Model power system data sheet	11
Table 2: Distance Zone parameters setting	11
Table 3: Case summary of fault distance and types	18

Executive Summary

Our project focus on the line to line relay protection testing and fault analysis with GPS coordinated. This is a new kind of relay protection. In our project modeling and simulation part, we created a 230KV transmission line system with two SEL421 relays to test this new method's behavior. Because of their time-aligned information, it is available to let different place relay see the fault based on the coordinated time. This is also help for the after fault analysis of fault current, voltage magnitude and angle change. In our experiment part, we used both SEL 311L and SEL 421 relay with Doble F6150A power simulator to test this new method, and got the fault waveform and text output. Furthermore, we discussed its future protection applications on distance relay back up (Zone 3) scheme, large-scale power system using and new out-of-step protection algorithm building.

Key word: Distance Protection analysis; GPS coordinated Relay; Power simulator Testing; SEL421 Relay analysis; Backup Protection Improvement; Out-of-Step Protection improvement;

1. Introduction

Development of modern communication technology and the need for selectivity of switched line faults in the shortest time, have inspired power system protection communications schemes for line current differential, phase comparison and distance protection communication based protection [1-22].

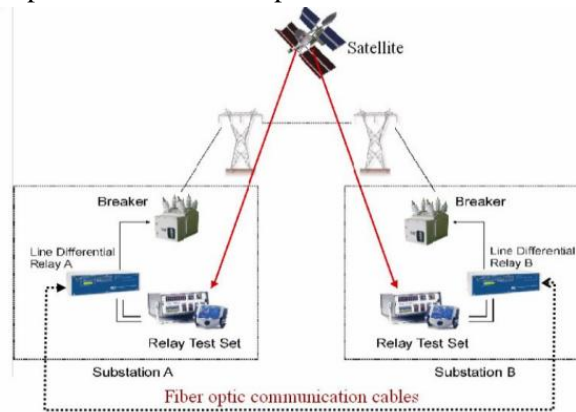

Figure 1: Relay with GPS coordinated

For the modern smart power system, they need more and more relays could be able to transmit data and fault information based on a uniformed time zone. And also, it is a quite big challenge for relays, what will the relay system to see the line fault? How to deal with the two different side data? Right now the answer is belong to the WAMS and PMU devices[23,24]. Synchronized phasor measurement units (PMUs) were first introduced in early 1980s, then have become a mature technology with many applications [25-55]. With the occurrence of major blackouts in many power systems around the world, the value of data provided by PMUs has been recognized, and installation of PMUs on power transmission networks of most major power systems has become an important current activity[53,54].

The occurrence of major blackouts in many major power systems around the world has given a new impetus for large-scale implementation of wide-area measurement systems using PMUs and phasor data concentrators (PDCs) in a hierarchical structure[1,5,26-32]. Data provided by the PMUs are very accurate and enable system analysis to determine the exact sequence of events which have led to the blackouts, and help analyze the sequence of events which helps pinpoint the exact causes and malfunctions that may have contributed to the catastrophic failure of the power system[3,7,18-29].

As experience with WAMS is gained, it is natural that other uses of phasor measurements will be found. In particular, significant literature already exists which deals with application of phasor measurements to system monitoring, protection and control[56-71].

2. Background

2.1. Power system phasor definition

A pure sinusoidal waveform can be represented by a unique complex number known as a phasor. Consider a sinusoidal signal [1,3,12]:

$$x(t)=X_m\cos(\omega t+\phi) \quad (1)$$

The phasor representation of this sinusoid is given by[1,2,21]

$$X = \frac{X_m}{\sqrt{2}} e^{j\phi} = \frac{X_m}{\sqrt{2}} (\cos\phi + j\sin\phi) \quad (2)$$

2.2. Synchrophasor definition and measurements

Although a constant phasor implies a stationary sinusoidal waveform, in practice it is necessary to deal with phasor measurements which consider the input signal over a finite data window. In many PMUs the data window in use is one period of the fundamental frequency of the input signal. If the power system frequency is not equal to its nominal value (it seldom is), the PMU uses a frequency-tracking step and thus estimates the period of the fundamental frequency component before the phasor is estimated. It is clear that input signal may have harmonic or nonharmonic components. The task of the PMU is to separate the fundamental frequency component and find its phasor representation [1,31,37,50,71,73].

The most common technique for determining the phasor representation of an input signal is to use data samples taken from the waveform, and apply the discrete Fourier transform (DFT) to compute the phasor[2,14-19].

If $x_k(k=0,1,\dots,N-1)$ are the N samples of the input signal taken over one period, then the phasor representation is given by (3)

$$X = \frac{\sqrt{2}}{N} \sum_{k=0}^{N-1} X_k e^{-jk\frac{2\pi}{N}} \quad (3)$$

2.3. SEL421 relay connection

The SEL-421 Relay records power system events with very high accuracy when you provide high-accuracy clock input signals, such as from a GPS receiver. SEL-421 relays placed at key substations can give you information on power system operating conditions in real time [72].



Figure 2: SEL421 High-Speed line Protection, Automation, and Control System

Based on the high-accuracy time input, the relay calculates synchrophasors for current and line voltages(for each phase and for positive-sequence), as specified in C37.118, IEEE Standard for Synchrophasors for Power Systems [13-15].The whole SEL421 relay function box can be organized in Fig.3.

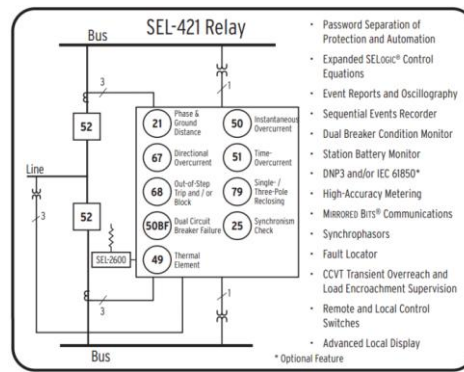

Figure 3: SEL421 relay function box

Our relay, the SEL-421, can be configured to work as a PMU, which stands for Phasor Measurement Unit. PMU, or otherwise known as synchrophasor, is a device that measures electrical waves on an electricity grid using a common time source for synchronization. This allows us to take synchronized real-time measurements of multiple measured points on the grid. Synchrophasors are one of the most important measuring devices for the future of power systems. The GPS in our system is what makes the synchrophasor measurements possible.

The PMU has 6 current channels and 6 voltage channels. From these 12 channels, the PMU can measure up to 20 synchrophasors. 15 of those are 15 phase synchrophasors and 5 are positive-sequence synchrophasors. The global enable setting EPMU must be set to Y before the remaining synchrophasor settings are available. The PMU can be configured to process C37.118 synchrophasor data received from two remote PMUs over serial ports. The PMU processes the remote PMU data, time aligns them with the local data, and makes them available as analogs and digitals. Use the local synchrophasor analogs and as many as two remote sets of synchrophasor analogs in SELOGIC equations to do real-time control applications. The rate at which to expect messages from the remote synchrophasor device is RTCRATE. MRTCDLY selects the maximum acceptable delay for received synchrophasor messages. PMUMODE is used when you want to use the port to receive synchrophasor data from another device. Set this setting to either CLIENTA or CLIENTB.

The PMU can be configured to record synchrophasor data by setting EPMDR := Y. Select one of the data configuration q you want to record using SPMDR setting where $q = 1 - \text{NUMPHDC}$. Create a recording trigger using PMTRIG SELOGIC setting. On the rising edge of PMTRIG, the PMU starts recording synchrophasor data and the duration and the pretrigger duration of the recording are user settable. The EPMDR setting is used to enable synchrophasor data recording. The PMLER sets the total length of the synchrophasor data recording in seconds. The PMPRE sets the length of the pretrigger data within the synchrophasor data recording.

Fig.4 shows how the PMU uses signal processing to measure the synchrophasors. The basic flow of how this works is that an input signal gets passed through a low-pass filter which transforms it into two sinusoids. Each sinusoid is 90 degrees apart from each other to produce real and imaginary parts of the synchrophasor. Then they are synchronized to absolute time. This is done to provide an absolute time reference so it can be tracked for the synchrophasor. The output is the magnitude and angle of the synchrophasor.

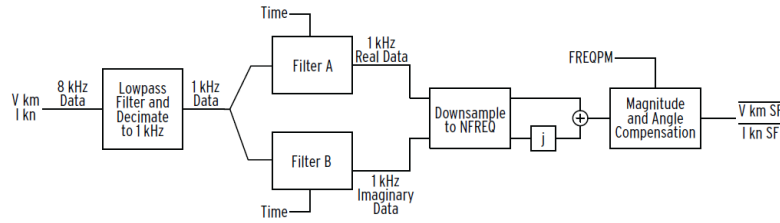

Figure 4: Diagram of How the Synchrophasor Processes Data

Now we will describe a bit about how the synchrophasor frequency is calculated. The PMU calculates the frequency by using the following formula. θ_k is the V1nPMA and θ_{k-1} is the V1nPMA, but just one cycle before it. Δt of course is just the time difference between the angle calculations.

$$f_k = \frac{(\theta_k - \theta_{k-1})}{\Delta t * 360}$$

Then the PMU will average the frequency just as shown below.

$$f_{avg_k} = \frac{(\sum_{n=0}^9 f_{k-n}) - f_{max1} - f_{max2} - f_{min1} - f_{min2}}{6}$$

This will happen if PMFRQA = S

$$f_{avg_k} = \frac{(\sum_{n=0}^3 f_{k-n}) - f_{max} - f_{min}}{2}$$

This will happen if PMFRQA = F

The rate of change of the frequency will then be calculated by the PMU by the following equation.

$$dfdt_k = \frac{(f_{ave_k} - f_{ave_{k-1}})}{\Delta t}$$

2.4. SEL311L relay settings



Figure 5: SEL311L line current differential protection

SEL311L is a line current differential protection and automation relay, which can also connect to GPS signals. It also has the synchrophasor function box which can work well with SEL GPS 2407 [73]. What's more, this relay has a higher tolerance of GPS signals time delay than SEL421, so in the test part, we also use this relay to test the system.

2.5. GPS clock connection

Our Project is using GPS equipment called SEL-2407 to input time signal into relay equipment. The SEL-2407 has high-accuracy timing application for SEL-421, our relay equipment. This part will introduce how to connect, set up and test these equipments for simulation [74].



Figure 6: SEL2407 GPS Clock

SEL-2407 has a good performance about providing accurate time signal, such as ± 100 ns of UTC. In the application of synchronized sampling in the SEL 421, it just require clock source with ± 500 ns accuracy. Hence, SEL-2407 could assure real-time in simulation of relay with respect of this project.

2.6. SEL 3351 system computing platform



Figure 7: SEL system computing platform

This device is SEL's embedded automation computing platform, which is built to withstand harsh environments in utility substations and industrial control and automation systems [75]. This device has multi I/O part and special designed hardware and framework to collect the data from all kinds of Relays. It can also works as an normal data concentrator and local controller. In this reports, we are using SEL 3351 to connect and control the SEL 421 relay.

2.7. Doble Power System Simulator

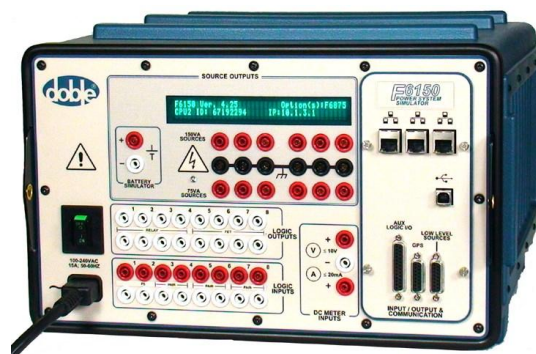

Figure 8: Doble F6150A power simulator

Doble F6150A power simulator is a relay testing device which can supply 3 phase voltage and current in separated ports [76]. It has a software which can mimic a virtual manual control panel for people to input the data. Besides this, it also has a industrially used automatic function---“MACRO”, which can create a testing plan and allow tester to use ATP simulation waveform to test the relay.

In this report, we think this model using more lab stuff than real industrial equipment. We want to see the real relays, like SEL421, its behavior on GPS synchronized system. So based on this previous work, we recreate our model and use SEL421 and GPS clock2407 and its software to build our grid. For the further fault signal testing, we use double power simulator to give variable current and voltage to mimic different situations.

3. Proposed Approach

3.1. Relay Testing Power System Modeling Build

The test setup consists of a power system model in real-time simulator and two SEL-421 relays connected in a closed loop fashion, as shown below. The two relays are time synchronized to a GPS clocker. The power system models assuming are two 230KV generator, transferring power through parallel transmission lines, line 1 and line 2. The two SEL-421 relays protect the line and measure the synchrophasor data.

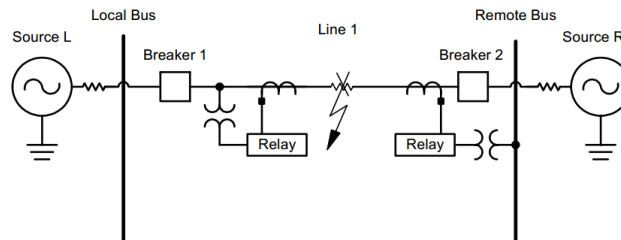

Figure 9: Power protection testing model

Parameter	Value
Positive-sequence line impedance	39@84 ohms
Zero-sequence line impedance	124@81.5 ohms
Source impedance ($Z_{1S}=Z_{0S}$)	50@86 ohms
PTR	2000
CTR	100
Phase Rotation	ABC

Table 1: 230kV Model power system data sheet

Parameters	Value
(Zone1) Z_{1mag}	1.95
Z_{1ang}	84
(Zone2) Z_{2mag}	6.2
Z_{2ang}	81.5
Maximum load current is 495A (primary)	
Line length 50 miles	

Table 2: Distance Zone parameters setting

In this report's simulation, we use the SEL standard relay testing model---230kV Overhead line distance protection model. The detailed setting values are shown in Tab.1 and Tab.2. The overview

system shows like in Fig.7.

3.2. Relay Fault Behavior Testing with ASPEN software

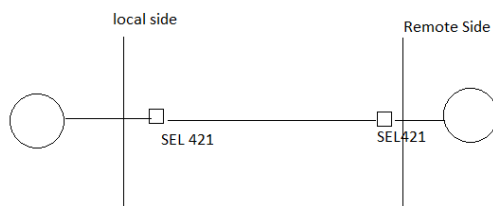

Figure 10: Simply model for software simulation

We set the SEL421 relays to operate zone1 and zone 2 distance protection, also we test the SEL 311L with overcurrent protection. We also used a POTT scheme to improve security. Table 1 shows the system data used for this report. Fig.9 shows the Aspen simulation diagram.

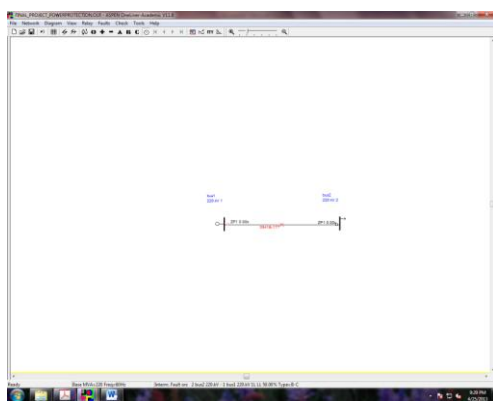

Figure 11: Aspen simulation

For the relay type chosen, because the ASPEN software right now do not have the appropriate SEL 4XX level for using, we are trying to use the most similar one. In this experiment, we will mainly use the relay line protection function, which can be replaced by SEL211. For the relay settings, we use phase Distance relay type.

3.3. Relay Testing with Doble F6150A and ATP

The powerful system simulator machine, Doble F6150A can not only simulate the fault current and voltage by manual control panel, but also do automatic large scale fault simulations with ATP data. They allow us to use Doble Macro function tools to create transient situations to test complex relay. In this time, we use the EE 5224 power protection lab model to test our system of left side. The ATP

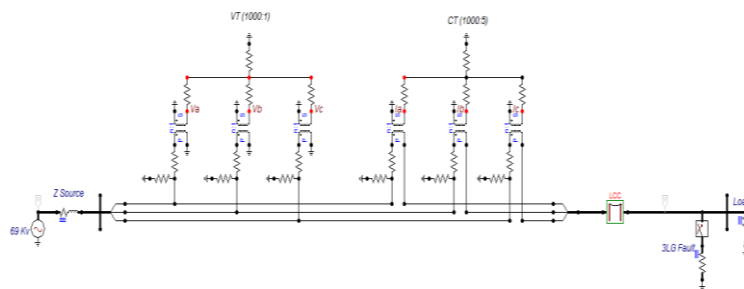

Figure 12: Atp model for simulation

4. Result

4.1. ASPEN Simulation Result

Line to line fault at the middle of line.

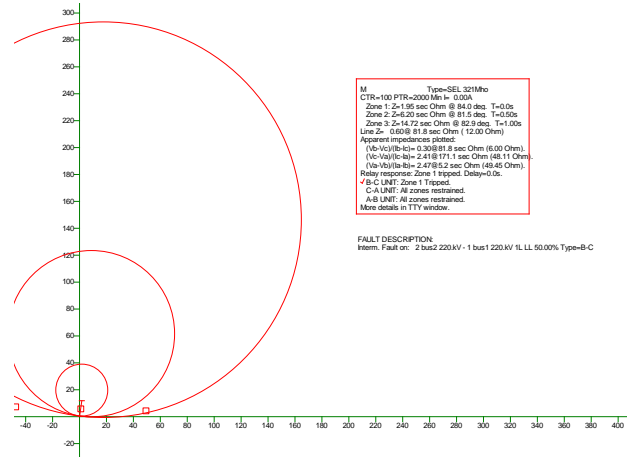

Figure 13: Aspen result for distance protection

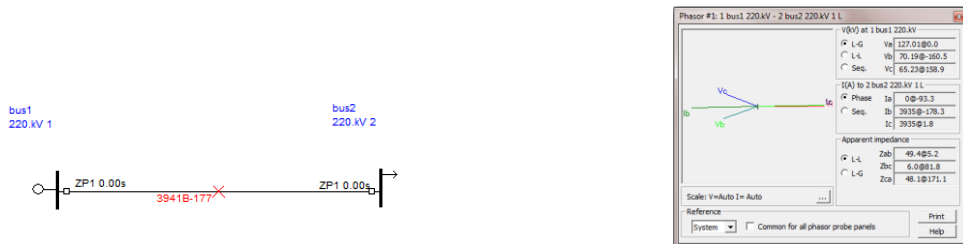

Figure 14: Result of Line to line middle fault

Line to ground fault

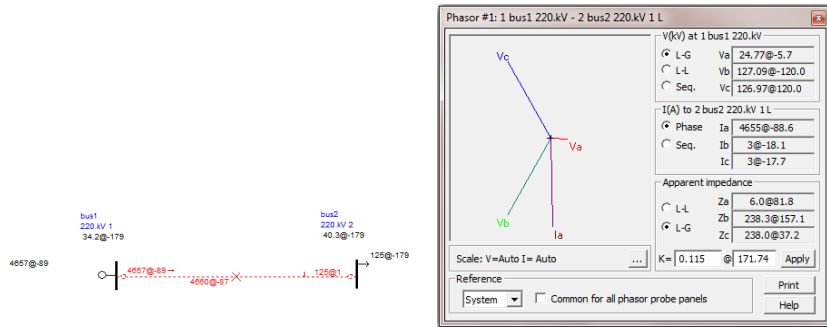

Figure 15: Aspen result of line to ground fault

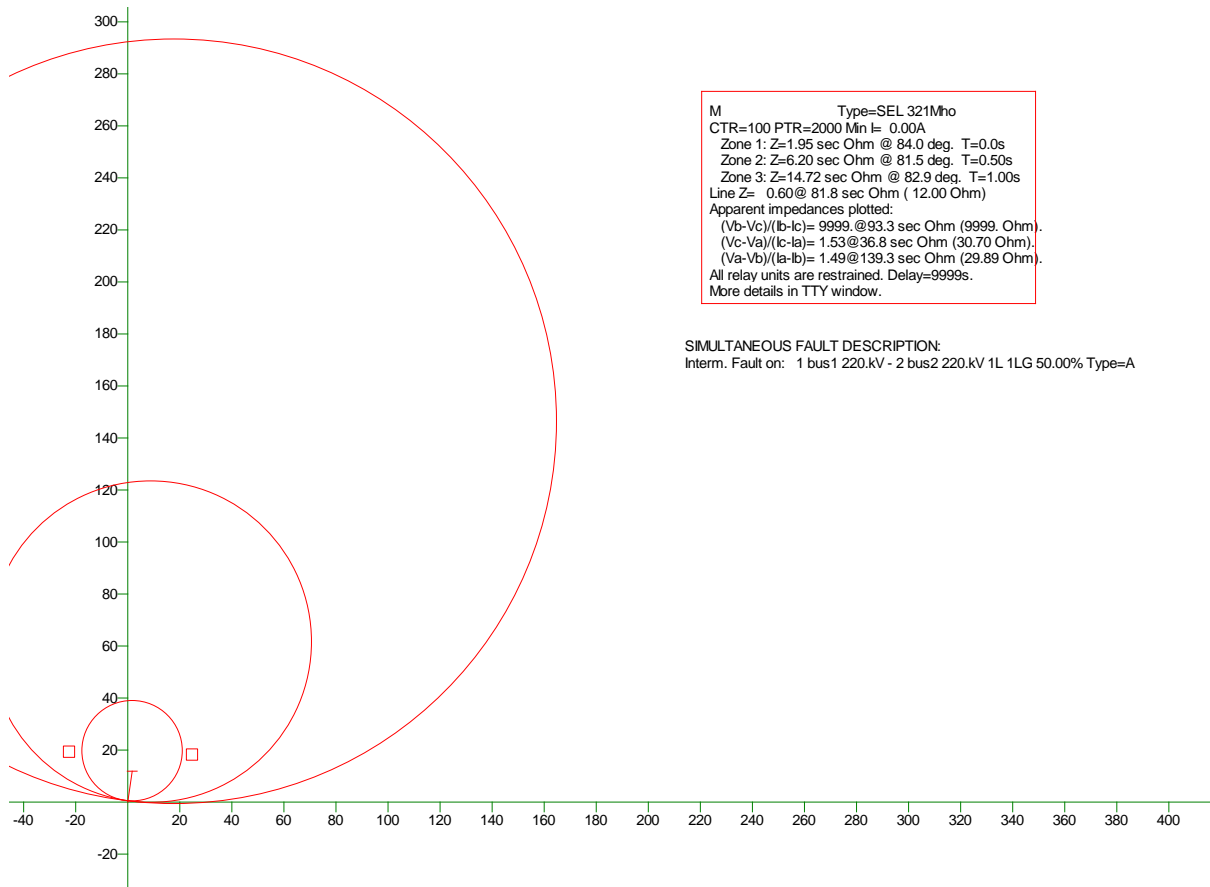

Figure 16: relay result of line to ground fault

Line to line fault at the line end

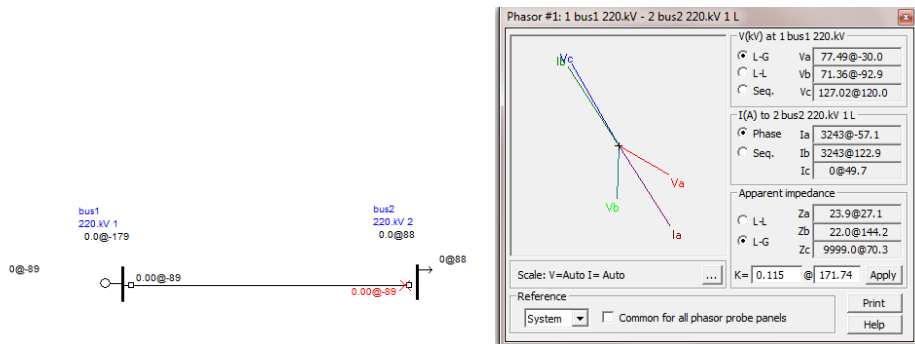

Figure 17: Aspen result of Line to Line fault at the line end

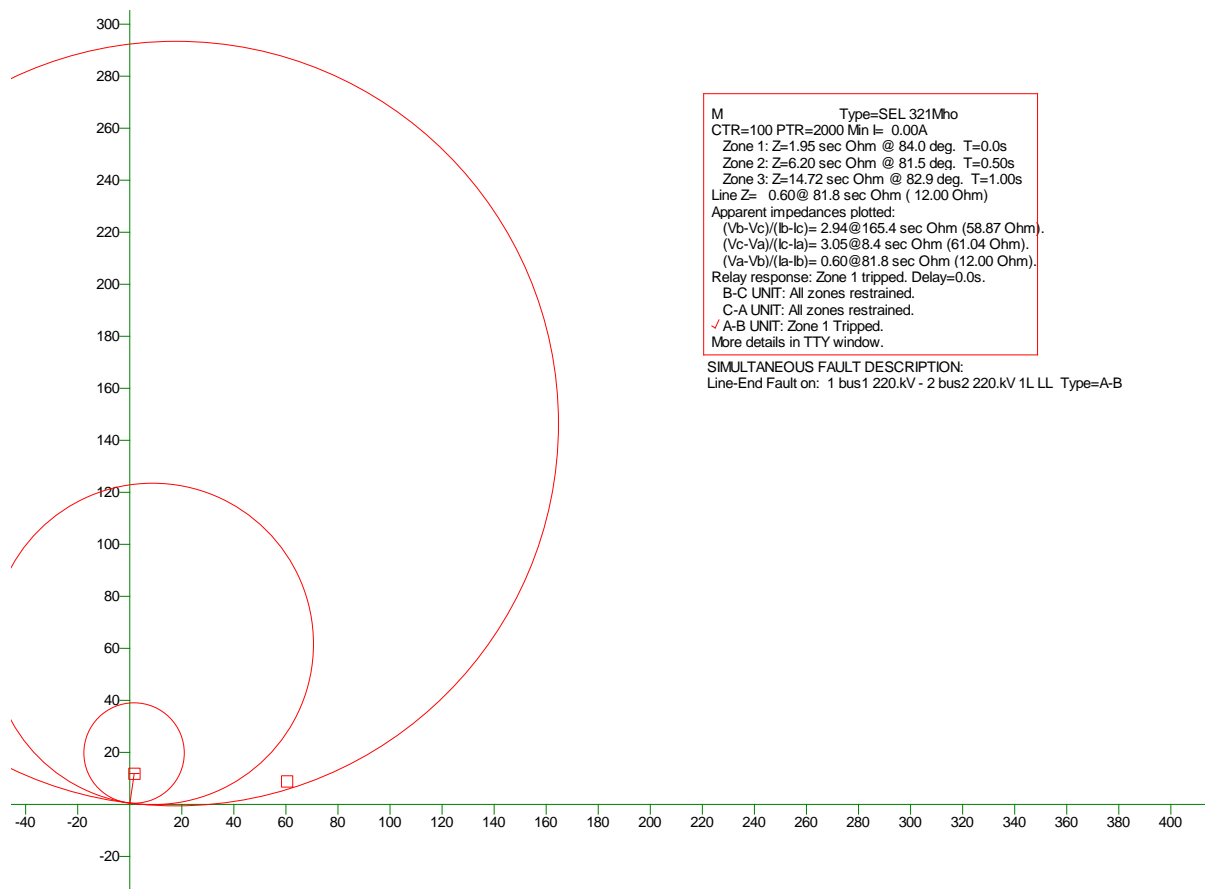

Figure 18 : Relay trip result of Line end fault

Line to line fault at close in fault

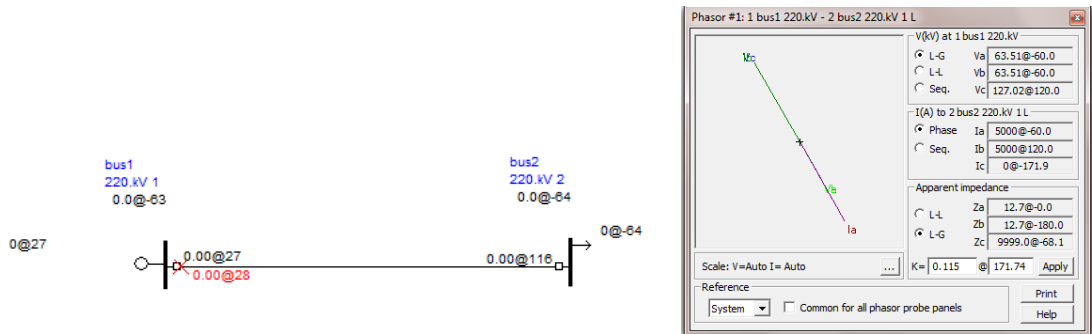

Figure 19: Aspen result of line to line fault at close in fault

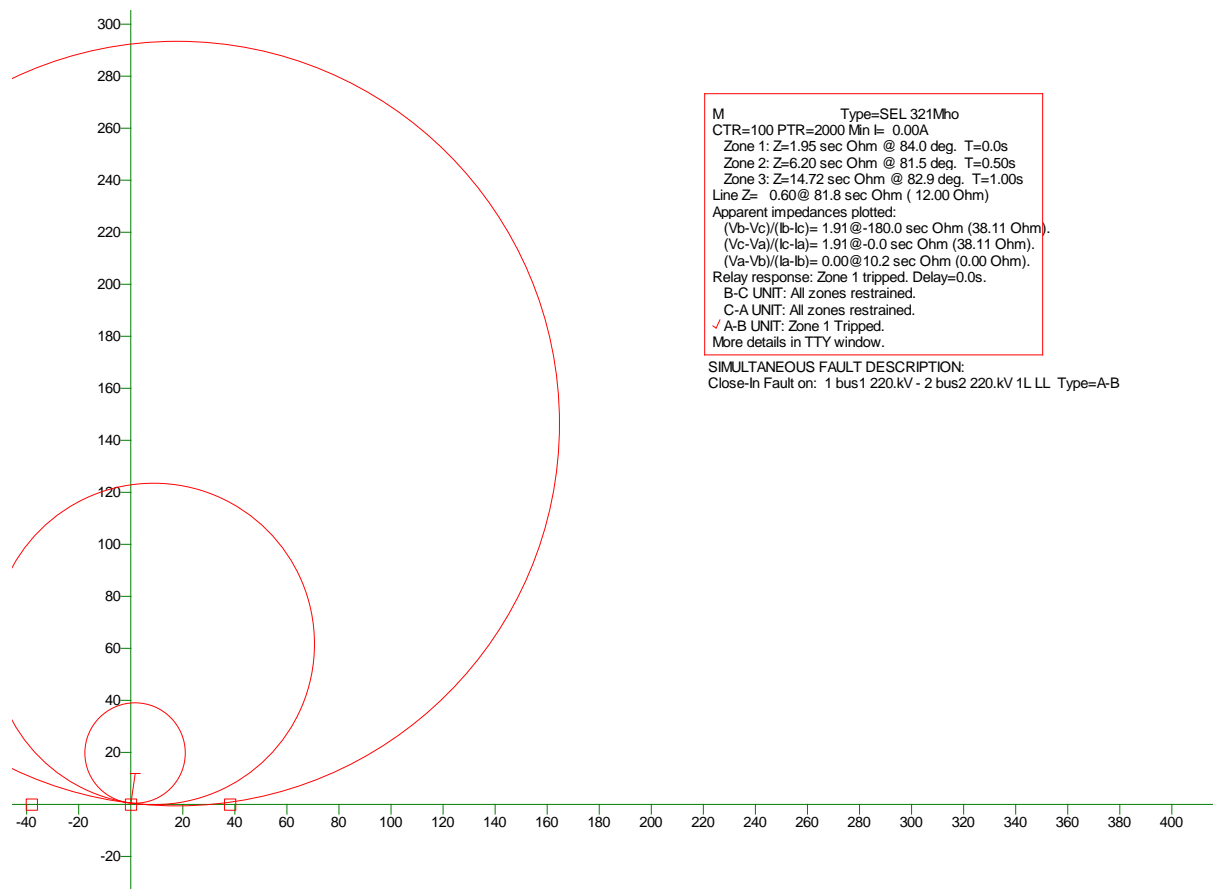

Figure 20: Relay trip result of line to line fault at close in fault

4.2. Experiments Result

For our system, we are going to have two results. First, we will evaluate the relay device when we finished the building process by testing relay in two situations (with or without GPS signals). Second, we will evaluate this system stability or other dynamic abilities when we add some fault situation into relay.

Without using SEL 421 unit, we used SEL311L to achieve our goals. Then reason of this replace is SEL 421 device needs more accuracy cables and GPS time intervals setting, which we cannot reach by existed equipment. Our cables are normal communication wire which be used as electronic signal control, but here relay needs a High IRIB cable, more or less like fiber optic one.

Because of this, the relay 421 is very often to show the “Aborted, High Accuracy Time needed!” error.

But for SEL 311L, this relay can handle larger time delay and able to correlate with normal GPS signal communication cables.

4.2.1. Relay fault with GPS coordinated

In this part, we used the ATP model to generate a .pl4 file with several seconds. Using double macro function, which shows in Fig.21, we can mimic a fault waveform to our relay. Fig.22 shows the HMI interface with GPS signals. And the Fig.23 shows the relay event viewer embedded in AcSelerator software. Because of lacking the PDC equipment, we cannot combine two different relay data into one diagram to compare their wave, but we still can see their waveform separately.

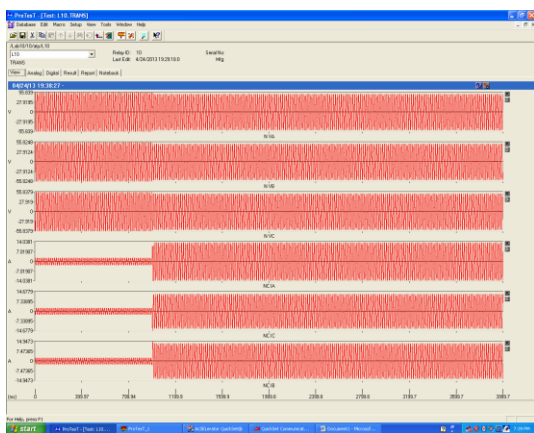

Figure 21: Double Macro Settings

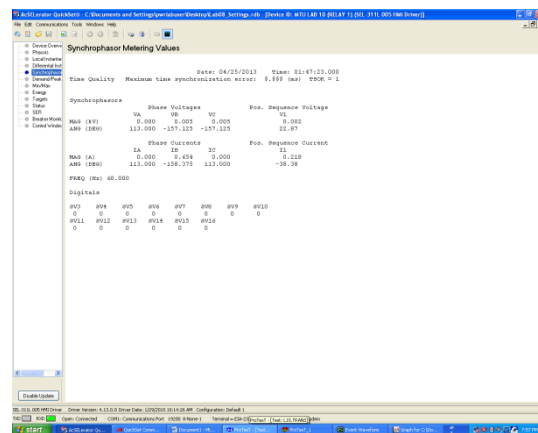
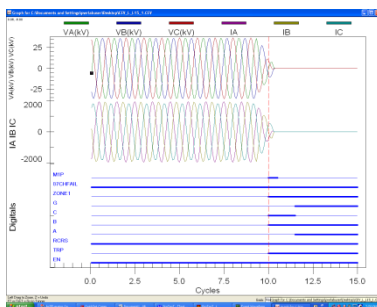
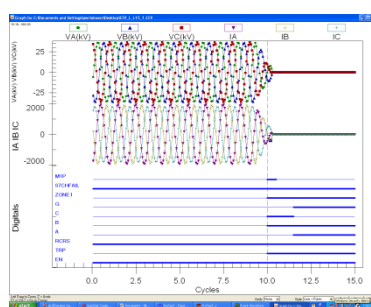

Figure 22: Relay GPS coordinated information



Relay Trip event for analysis



Trip data in dots

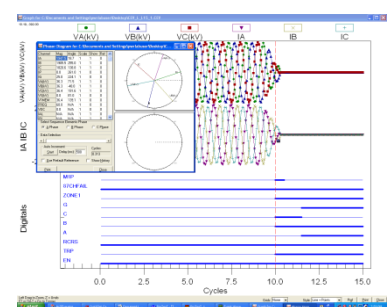

Trip data with phasor information

Figure 23: Relay Event for tripping analysis

4.2.2. Relay trip result comparison

In this part, we do the same fault trip time collections to compare the relay with or without GPS signals different. In Fig.24 and Fig.25, it shows the comparison result of several cases.

Case	Fault distance(percentage)		Fault type
	Local	remote	
1	10	90	AB ABC
2	30	70	AB ABC
3	50	50	AB ABC
4	70	30	AB ABC
5	80	20	AB ABC
6	90	10	AB ABC

Table 3: Case summary of fault distance and types

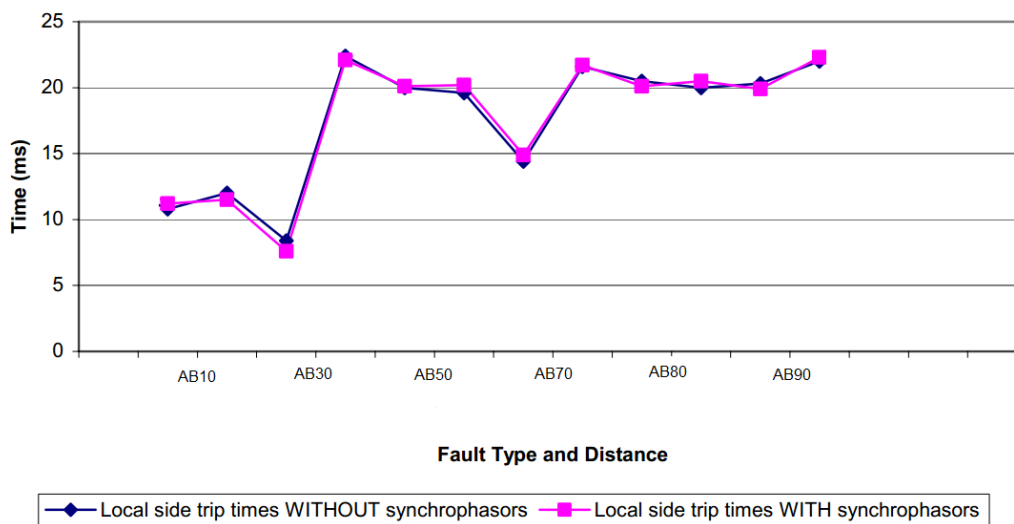

Figure 24: Relay with line to line fault comparison

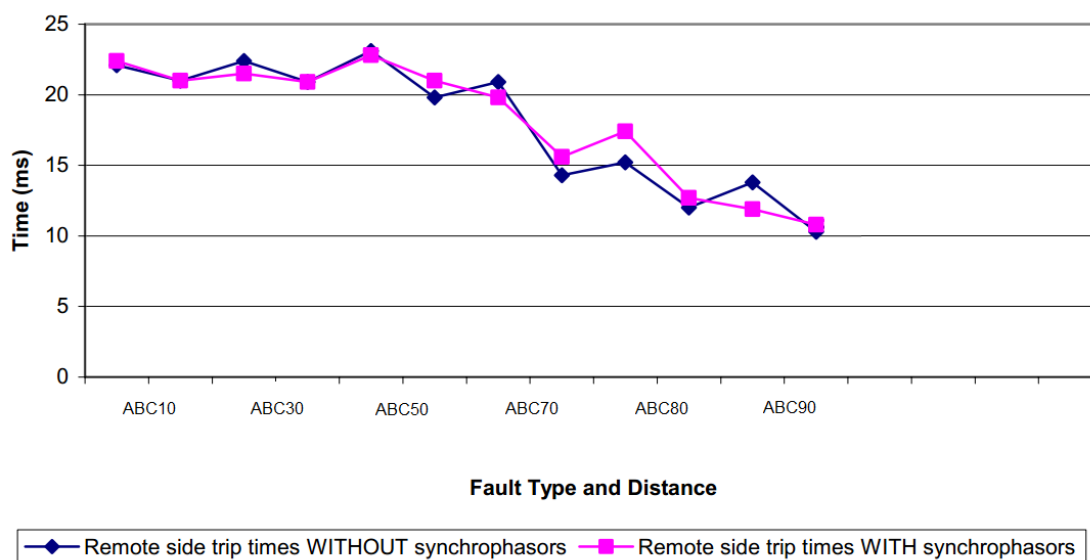

Figure 25: Relay with 3-phase fault comparison

5. Recommendation of future work

5.1. Improve system scale to test the performance

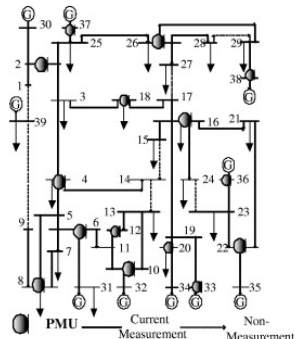

Figure 26: multi-PMU system configuration

By now we are only dealing with a two-terminal system. For future work, we are going to add some more relay into this system, like in Fig.15, mimics a three generator nine buses IEEE standard system to a more complex grid relay protection behavior[1,20-35].

5.2. Analysis relay Zone-3 protection with GPS coordinated

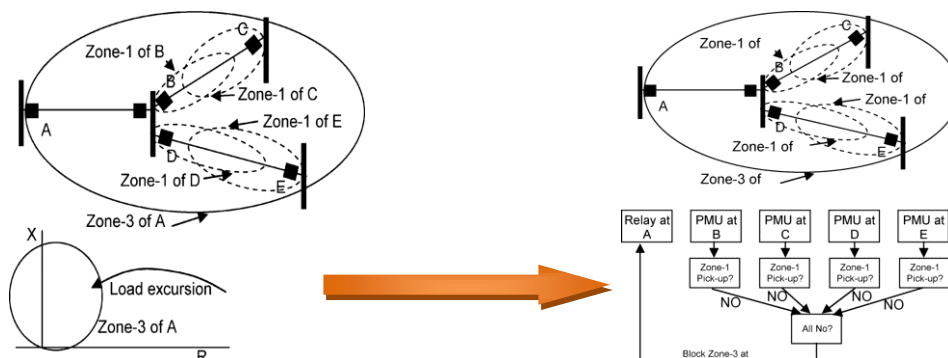

Figure 27: Zone 3 protection with PMU devices

From the Fig.27. , the loadability limit imposed by zone-3 setting of a distance relay. This relay has a MHO characteristic, which is commonly used. As the load increases along the bold arrow, it would enter the tripping zone of the relay and cause an inappropriate trip [1,56-62]. For such locally power protections, the latency of communicating information from remote sites are vital disadvantages. Therefore with synchronized phasor measurement's help, it may solve these complex protection problems, as shown in Fig.16.

State of contribution

Project member: Yawei Wei; Zhe Qin; Justin Sliva;

Yawei Wei System building and part of report writing

Zhe Qin System building and part of report writing

Justin Sliva System building and part of report writing

Reference

- [1] De La Ree, J.; Centeno, V.; Thorp, J.S.; Phadke, A.G., "Synchronized Phasor Measurement Applications in Power Systems," *Smart Grid, IEEE Transactions on* , vol.1, no.1, pp.20,27, June 2010
- [2] Chih-Wen Liu; Tzu-Chiao Lin; Chi-Shan Yu; Jun-Zhe Yang, "A Fault Location Technique for Two-Terminal Multisection Compound Transmission Lines Using Synchronized Phasor Measurements," *Smart Grid, IEEE Transactions on* , vol.3, no.1, pp.113,121, March 2012
- [3] Dam, Q.B.; Mohagheghi, S.; Alaieh, R.H.; Stefopoulos, G.K.; Cokkinides, G.J.; Meliopoulos, A. P S, "A laboratory setup for relay and GPS-synchronized equipment transient testing," *Power and Energy Society General Meeting - Conversion and Delivery of Electrical Energy in the 21st Century, 2008 IEEE* , vol., no., pp.1,8, 20-24 July 2008
- [4] Makarov, Y.V.; Pengwei Du; Shuai Lu; Nguyen, T.B.; Xinxin Guo; Burns, J.W.; Gronquist, J.F.; Pai, M.A. "PMU-Based Wide-Area Security Assessment: Concept, Method, and Implementation", *Smart Grid, IEEE Transactions on*, vol.3, no.3, pp: 1325 – 1332, Sept. 2012
- [5] Xue Cao; Abdulhadi, I.; Booth, C.; Burt, G. "Defining the role of wide area adaptive protection in future networks", *Universities Power Engineering Conference (UPEC)*, 2012 47th International, pp: 1 - 6
- [6] Hall, I.; Beaumont, P.G.; Baber, Gareth P.; Shuto, I.; Saga, M.; Okuno, K.; Uo, H., "New line current differential relay using GPS synchronization," *Power Tech Conference Proceedings, 2003 IEEE Bologna* , vol.3, no., pp.8 pp. Vol.3, 23-26 June 2003
- [7] Zambrano, A.A.; Leon, M.A.; Rivas, E. "Phasor measurement unit using GPRS wireless connectivity", *Innovative Smart Grid Technologies (ISGT Latin America), 2011 IEEE PES Conference on*, pp: 1 - 7
- [8] Zhengtian Li; Xiangning Lin; Hanli Weng; Zhiqian Bo "Efforts on Improving the Performance of Superimposed-Based Distance Protection", *Power Delivery, IEEE Transactions on*, vol. 27, no.4, pp: 186 – 194, Jan. 2012
- [9] Lillian, M.; Thompson, S.L., "GPS satellite synchronized test systems recreate fault conditions to troubleshoot protective relay schemes," *Developments in Power System Protection, Sixth International Conference on (Conf. Publ. No. 434)* , vol., no., pp.346,350, 25-27 Mar 1997
- [10] Salehi, V.; Mohamed, A.; Mazloomzadeh, A.; Mohammed, O.A. "Laboratory-Based Smart Power System, Part I: Design and System Development", *Smart Grid, IEEE Transactions on*, vol.3, Issue: 3, pp: 1394 – 1404, Sept. 2012
- [11] Soni, S.; Bhil, S.; Mehta, D.; Wagh, S. "Linear state estimation model using phasor measurement unit (PMU) technology", *Electrical Engineering, Computing Science and Automatic Control (CCE), 2012 9th International Conference on*, pp: 1 - 6
- [12] Hadidi, R.; Jeyasurya, B. "Reinforcement Learning Based Real-Time Wide-Area Stabilizing Control Agents to Enhance Power System Stability", *Smart Grid, IEEE Transactions on*, vol.4, no.1, pp: 489 - 497 , March 2013
- [13] Zhiqin He; Zhe Zhang; "Wide-Area Backup Protection Algorithm Based on Fault Component Voltage Distribution", *Power Delivery, IEEE Transactions on*, vol.26, no.4, pp: 2752 – 2760, Oct. 2011
- [14] Yufan Guan; Kezunovic, M.; Sprintson, A.; Muxi Yan "Verifying interoperability and application performance of PDCs in synchrophasor system solution", *North American Power Symposium (NAPS)*, 2012, pp: 1 - 6
- [15] Yafei Yang; Xiaohong Guan; Yuxun Zhou; Jiang Wu; Ting Liu "Impact of information security on PMU-based distributed state estimation", *Innovative Smart Grid Technologies - Asia (ISGT Asia)*, 2012 IEEE, pp: 1 - 4
- [16] Rao, J.G.; Pradhan, A.K. "Application of synchrophasor data for fault detection during power swing", *Energy, Automation, and Signal (ICEAS)*, 2011 International Conference on, pp: 1 - 5
- [17] Junjie Tang; Junqi Liu; Ponci, F.; Monti, A.; Muscas, C.; Sulis, S. "Impact of synchrophasor measurement uncertainty on detecting voltage stability margin in power

- systems", *Innovative Smart Grid Technologies (ISGT Europe)*, 2012 3rd IEEE PES International Conference and Exhibition on, pp: 1 - 6
- [18] Yi Deng; Hua Lin; Phadke, A.G.; Shukla, S.; Thorp, J.S.; Mili, L. "Communication network modeling and simulation for Wide Area Measurement applications", *Innovative Smart Grid Technologies (ISGT)*, 2012 IEEE PES, pp: 1 - 6
- [19] Salehi, V.; Mazloomzadeh, A.; Fernandez, J.F.; Mohammed, O.A. "Real-time power system analysis and security monitoring by WAMPAC systems", *Innovative Smart Grid Technologies (ISGT)*, 2012 IEEE PES, pp: 1 - 8
- [20] Hui Deng; Jinquan Zhao; Xiaochen Wu; Kun Men "Real time transient instability detection based on trajectory characteristics and transient energy", *Power and Energy Society General Meeting*, 2012 IEEE, pp: 1 - 7
- [21] Hadidi, R.; Jeyasurya, B. "A real-time multiagent wide-area stabilizing control framework for power system transient stability enhancement", *Power and Energy Society General Meeting*, 2011 IEEE, pp: 1 - 8
- [22] Gang Chen; Yuanzhang Sun; Venkatasubramanian, V.; Lin Cheng; Jin Lin; Bose, A.; Weixing Zhao; Cheng Lin "Wide area control framework design considering different feedback time delays", *Power and Energy Society General Meeting*, 2012 IEEE, pp: 1 - 8
- [23] Jian Chen; Shrestha, P.; Shun-Hsien Huang; Sarma, N.D.R.; Adams, J.; Obadina, D.; Ballance, J. "Use of synchronized phasor measurements for dynamic stability monitoring and model validation in ERCOT", *Power and Energy Society General Meeting*, 2012 IEEE, pp: 1 - 7
- [24] Hines, P.D.H.; Cotilla-Sanchez, E.; O'hara, B.; Danforth, C. "Estimating dynamic instability risk by measuring critical slowing down", *Power and Energy Society General Meeting*, 2011 IEEE, pp: 1 - 5
- [25] Salehi, V.; Mazloomzadeh, A.; Mohammed, O. "Development and implementation of a phasor measurement unit for real-time monitoring, control and protection of power systems", *Power and Energy Society General Meeting*, 2011 IEEE, pp: 1 - 7
- [26] Salehi, V.; Mazloomzadeh, A.; Mohammed, O. "Real-time analysis for developed laboratory-based smart micro grid", *Power and Energy Society General Meeting*, 2011 IEEE, pp: 1 - 8
- [27] Jian Chen; Shrestha, P.; Shun-Hsien Huang; Sarma, N.D.R.; Adams, J.; Obadina, D.; Ballance, J. "Use of synchronized phasor measurements for dynamic stability monitoring and model validation in ERCOT", *Power and Energy Society General Meeting*, 2012 IEEE, pp: 1 - 7
- [28] Hines, P.D.H.; Cotilla-Sanchez, E.; O'hara, B.; Danforth, C. "Estimating dynamic instability risk by measuring critical slowing down", *Power and Energy Society General Meeting*, 2011 IEEE, pp: 1 - 5
- [29] Salehi, V.; Mazloomzadeh, A.; Mohammed, O. "Development and implementation of a phasor measurement unit for real-time monitoring, control and protection of power systems", *Power and Energy Society General Meeting*, 2011 IEEE, pp: 1 - 7
- [30] Salehi, V.; Mazloomzadeh, A.; Mohammed, O. "Real-time analysis for developed laboratory-based smart micro grid", *Power and Energy Society General Meeting*, 2011 IEEE, pp: 1 - 8
- [31] Heydt, G. T. "The Next Generation of Power Distribution Systems", *IEEE Transactions on Smart Grid*, **vol.1**, no.3, pp.225, 2010
- [32] Kim, T.T.; Poor, H.V. "Strategic Protection Against Data Injection Attacks on Power Grids", *Smart Grid, IEEE Transactions on*, **vol.2**, no.2, pp.326 - 333, June 2011
- [33] Susuki, Y.; Koo, T.J.; Ebina, H.; Yamazaki, T.; Ochi, T.; Uemura, T.; Hikiyara, T. "A Hybrid System Approach to the Analysis and Design of Power Grid Dynamic Performance", *Proceedings of the IEEE*, **vol.100**, no.1, pp: 225 - 239, Jan. 2012
- [34] Cotilla-Sanchez, E.; Hines, P.D.H.; Danforth, C.M. "Predicting Critical Transitions From Time Series Synchrophasor Data", *Smart Grid, IEEE Transactions on*, **vol.3**, no. 4, pp: 1832 - 1840, Dec. 2012
- [35] Jinfeng Ren; Kezunovic, M. "An Adaptive Phasor Estimator for Power System Waveforms Containing Transients", *Power Delivery, IEEE Transactions on*, **vol. 27**, no. 2, pp: 735 - 745, April 2012
- [36] Jihun Kim; Byongjun Lee; Sangwook Han; Jeong-Hoon Shin; Taekyun Kim; Sangtae Kim; Younghwan Moon "Study of the Effectiveness of a Korean Smart Transmission Grid Based on Synchrophasor Data of K-WAMS", *Smart Grid, IEEE Transactions on*, **vol. 4**, no.1, pp. 411 - 418, March 2013
- [37] Qing Zhang; Vittal, V.; Heydt, G.T.; Logic, N.; Sturgill, S. "The Integrated Calibration of Synchronized Phasor Measurement Data in Power Transmission Systems", *Power Delivery, IEEE Transactions on*, **vol.26**, no.4, pp: 2573 - 2581, Oct. 2011
- [38] Sangwook Han; Byongjun Lee "Wide area monitoring system for the Korean smart transmission grid using PMUs", *Advanced Power System Automation and Protection (APAP)*, 2011 International Conference on, **vol.3**, pp: 1990 - 1995, Oct. 2011
- [39] Sadinezhad, I.; Agelidis, V.G. "Extended staggered under sampling synchrophasor estimation technique for wide-area measurement systems", *Innovative Smart Grid Technologies Asia (ISGT)*, 2011 IEEE PES, pp: 1 - 7.
- [40] Kun Men; Peng Xu; Jinquan Zhao; Xiaochen Wu; Chao Hong "Comparison of methods for the perturbed trajectory prediction based on wide area measurements",

Power Engineering and Automation Conference (PEAM), 2011 IEEE, **vol. 3**, pp.321 - 325, Sept. 2011

- [41] Ramesh, V.; Khan, U.; Ilic, M.D. "Data aggregation strategies for aligning PMU and AMI measurements in electric power distribution networks", *North American Power Symposium (NAPS)*, pp: 1 - 7, 2011.
- [42] Yang Zhang; Bose, A. "PMU-based wide-area damping control system design", *Power and Energy Society General Meeting*, 2012 IEEE, pp.1 - 7
- [43] Qing Zhang; Vittal, V.; Heydt, G.; Chakhchoukh, Y.; Logic, N.; Sturgill, S. "The time skew problem in PMU measurements", *Power and Energy Society General Meeting*, 2012 IEEE, pp.1 - 6
- [44] Ren, J.; Kezunovic, M.; Guan, Y. "Verifying interoperability and application performance of PMUs and PMU-enabled IEDs", *Power and Energy Society General Meeting*, 2012 IEEE, pp.1 - 7
- [45] Hua Lin; Sambamoorthy, S.; Shukla, S.; Thorp, J.; Mili, L. "A study of communication and power system infrastructure interdependence on PMU-based wide area monitoring and protection", *Power and Energy Society General Meeting*, 2012 IEEE, pp.1 - 7
- [46] A. G. Phadke and J. S. Thorp *Synchronized Phasor Measurements and Their Applications*, 2008, Springer
- [47] "IEEE Standard C37.118-2005 (Revision of IEEE Std 1344-1995)", IEEE Standard for Synchrophasors for Power Systems.
- [48] R. O. Burnett , M. M. Butts , T. W. Cease , V. Centeno , G. Michel , R. J. Murphy and A. G. Phadke "Synchronized phasor measurement of a power system event", *IEEE Trans. Power Syst.*, **vol. 9**, no. 3, pp.1643 -1650 1994
- [49] D. Faulk and R. J. Murphy "Comanche peak unit no 2 100% load rejection test Under frequency and voltage phasor measured across TU electric system", *47th Annual Texas A&M Conf. Protective Relay Engineers*, 1994
- [50] Z. Zhong , C. Xu , B. J. Billian , L. Zhang , S.-J. S. Tsai , R. W. Conners , V. Centeno , A. G. Phadke and Y. Liu "Power system frequency monitoring network (FNET) implementation", *IEEE Trans. Power Syst.* **vol. 20**, no. 4, pp.1914 -1921,2005
- [51] R. F. Nuqui and A. G. Phadke "Phasor measurement placement techniques for complete and incomplete observability", *IEEE Trans. Power Del.*, **vol. 20**, no. 4, pp.2381 -2388, 2005
- [52] M. Zhou , V. A. Centeno , J. S. Thorp and A. G. Phadke "An alternative for including phasor measurements in state estimators", *IEEE Trans. Power Syst.*, **vol. 21**, no. 4, pp.1930 -1937, 2006
- [53] S. H. Horowitz and A. G. Phadke "Boosting immunity to blackouts", *IEEE Power Energy Mag.*, **vol. 1**, no. 5, pp.47 -53, 2003
- [54] S. H. Horowitz and A. G. Phadke "Third zone revisited", *IEEE Trans. Power Del.*, **vol. 21**, no. 1, pp.23 -29, 2006
- [55] A. G. Phadke , D. Novosel and S. H. Horowitz "Wide area measurement applications in functionally integrated power systems", *CIGRE B-5 Colloq.*, 2007
- [56] V. Centeno , A. G. Phadke , A. Edris , J. Benton , M. Gaudi and G. Michel "An adaptive out-of-step relay [for power system protection]", *IEEE Trans. Power Del.*, **vol. 12**, no. 1, pp.61 -71, 1997
- [57] V. Centeno , A. G. Phadke and A. Edris "Adaptive out-of-step relay with phasor measurement", *Proc. 6th Int. Conf. Developments in Power Syst. Protection*, pp.210 -213,1997
- [58] V. Centeno , A. G. Phadke , A. Edris , J. Benton and G. Michel "An adaptive out-of-step relay", *IEEE Power Eng. Rev.*, **vol. 17**, no. 1, pp.39 -40,1997
- [59] V. Centeno , J. De La Ree , A. G. Phadke , G. Michel , R. J. Murphy and R. O. Burnett Jr. "Adaptive out-of-step relaying using phasor measurement techniques", *IEEE Comput. Appl. Power*, **vol. 6**, no. 4, pp.12 -17,1993
- [60] S. H. Horowitz , A. G. Phadke and J. S. Thorp "Adaptive transmission system relaying", *IEEE Trans. Power Del.*, **vol. 3**, no. 4, pp.1436 -1445, 1988
- [61] D. Hu and M. Venkatasubramanian "New wide area algorithms for detection and mitigation of angle instability using synchrophasors", *Proc. Power Eng. Soc. General Meeting*, pp.1 -8, 2007
- [62] S. Rovnyak , C. W. Taylor and J. S. Thorp "Real-time transient stability prediction Possibilities for on-line automatic database generation and classifier training", *2nd IFAC Symp. Control of Power Plants and Power Syst.*, 1995
- [63] M. Venkatasubramanian , X. Yue , G. Liu , M. Sherwood and Q. Zhang "Wide-area monitoring and control algorithms for large power systems using synchrophasors", *Power System Conf. Exposition*, 2009
- [64] V. Madani , E. Taylor , D. Erwin , A. Meklin and M. Adamik "High speed control scheme to prevent instability of a large multi-unit power plant", *Clemson Power System Conf.*, 2007
- [65] Y. Zhang and A. Bose "Design of wide area damping controllers for interarea oscillations", *IEEE Trans. Power Syst.*, **vol. 23**, no. 3, pp.1136 -1143, 2008
- [66] N. Rostamkolai , A. G. Phadke , J. S. Thorp and W. F. Long "Measurement based optimal control of high voltage AC/DC systems", *IEEE Trans. Power Syst.*, **vol. 3**, no. 3, pp.1139 -1145, 1988

- [67] E. C. Manansala and A. G. Phadke "An optimal centralized controller with nonlinear voltage control", *Electric Mach. Power Syst.*, **vol. 19**, pp.139 -156 ,1991
- [68] A. F. Snyder , N. Hadsaid , D. Georges , L. Mili , A. G. Phadke , O. Faucon and S. Vitet "Inter-area oscillation damping with power system stabilizers and synchronized phasor measurements", *Proc. POWERCON\98*, **vol. 2**, pp.790 -794,1998
- [69] G. L. Yu , B. H. Zhang , H. Xie and C. G. Wang "Wide-area measurement-based nonlinear robust control of power system considering signal\’s delay and incompleteness", *Proc. Power Eng. Soc. General Meeting*, pp.1 -8 ,2007
- [70] X. Li , Q. Yan and Y. Hu "Decentralized coordinated robust adaptive control for AC/DC interconnected power system based on WAMS", *Proc. APCCAS 2008*, pp.1896 -1899 ,2008
- [71] C. Dou , S. Jin , Z. Bo , Q. Jia and H. Xue "Decentralized stabilizer design for model-based uncertain large interconnected power systems based on WAMS", *Proc. IPES 2007*, pp.799 -806, 2007.
- [72] SEL.inc. SEL 421 manual.2008
- [73] SEL.inc. SEL 311L manual.2008
- [74] SEL.inc. SEL GPS clock 2407 manual.2008
- [75] SEL.inc. SEL 3351 computing platform manual. 2006
- [76] Doble.coop. Doble F6150A manual.2008

Appendix

1. Working Schedule

- Week 6 Group meeting for our topic choosing and system building
- Week7 Group meeting for our future problem analyzing and literature searching
- Week8 Group work for basic relay model building and discussion about literature reviewing
- Week9 Group work for system building and basic testing
- Week10 Group discussion about our project writing and system analysis
- Week11 Group collaboration of project report draft writing and final system testing
- Week12 Submit the draft report and further system dynamic behavior testing
- Week13 Final conclusion of our system and preparing for the presentation
- Week14 Final Presentation and project hand in

2. Journal paper review

Journal Paper Review has been sealed in a separated assignment work, which has been submitted with an Assignment cover sheet.

3. GPS Setting Figures

3.1 Connection

Fig.28 shows basic method to connect relay SEL-421 and SEL-2407. In our project, we use newer relay hardware which only has one IRIG-B connector. This GPS equipment could report synchrophasor data to relay and achieve real-time and accurate application after right connection. Important notices are:

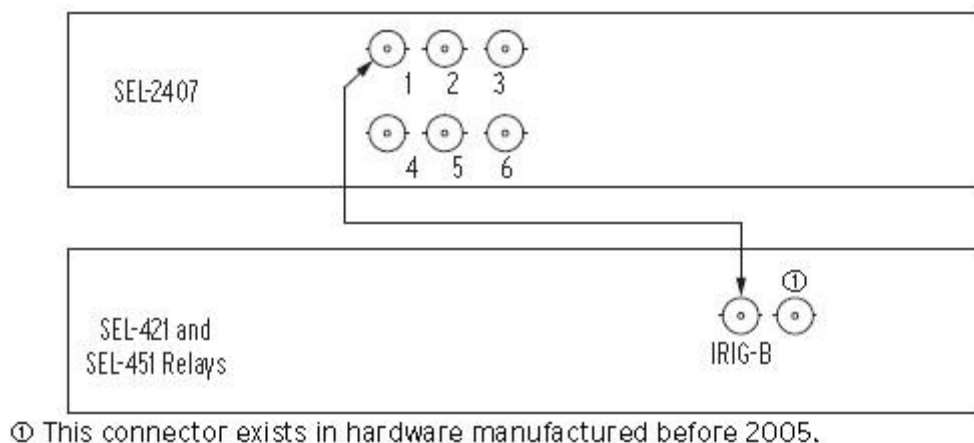

Figure 28: SEL 421 with GPS connection

3.2 Setting

Clock port settings for this application are shown in following steps:

Control (DIP) switch SW6, ON; control (DIP) switch SW7, ON (OUT1 set for IRIG-B000 with IEEE 1344 and IEEE C37.118 extensions format). IRIG-B is a serial data time format consisting of a 1-second frame that contains 100 pulses divided into fields. All remaining settings are default.

3.3 Test

In order to set the control (DIP) switches, removing the front panel is necessary. Using the serial port status command STA (which means request clock status and satellite signal strength) to verify settings is another way to check control (DIP) switch setting. Removing power is also imperative to avoid damage to the circuit board attached to the front panel. Fig.29 shows the control (DIP) and battery location.

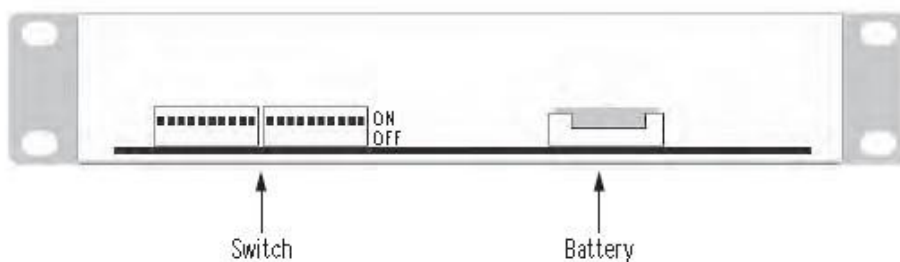

Figure 29: GPS testing

3.4 Specification

Receiver: Satellite Tracking: GPS L1, C/A Code (1575.42 MHz)

Acquisition Times: Typical cold start: 330s

Clock Accuracy: 1 PPS: ± 100 ns average, ± 500 ns peak

Antenna Requirements: 5V active antenna and 35 dB preamp

Electrical Output Drive Levels: Demodulated IRIG-B/PPS, TTL (OUT1-OUT6): 120 mA, 3.5 V dc, 25 ohms.

Power Supply: Rating: 24, 48, 125, 250 V dc; 120 and 230 V ac; 50/60 Hz

Range: 18-300 V dc or 85-264 V ac

Operating Temperature Range :-40 ° to +80 °

Humidity: 0% to 95% without condensation

Altitude: 2000 m maximum

4. SEL 421 Relay Setting Figures

The SEL-421 features two IRIG-B timekeeping modes, IRIG and high accuracy IRIG, called HIRIG. The HIRIG mode replaces the PPS mode in previous SEL-421-2 and SEL-421-3 relays, which required a separate 1K PPS time input in firmware versions R111 and earlier.

Word bit TSOK asserts when the SEL-421 is in HIRIG mode. And the SEL-421 must be in the HIRIG mode in order for synchrophasor features to operate.

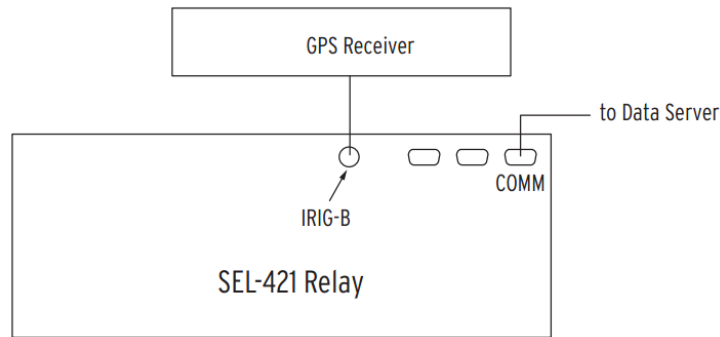

Figure 30: High-Accuracy Timekeeping Connections

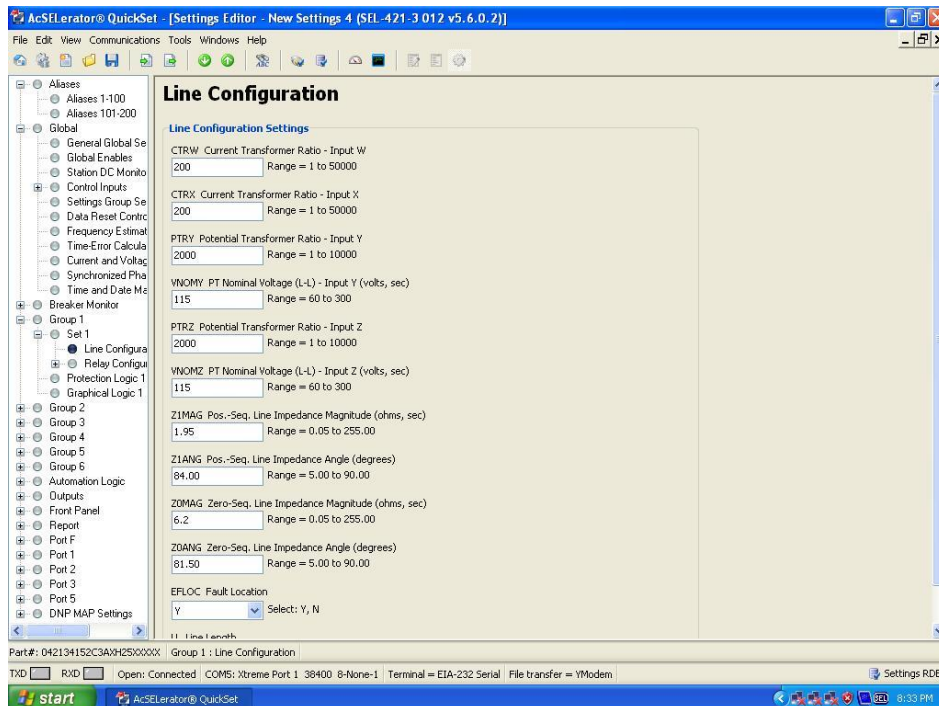

Figure 31: SEL421 Distance relay setting

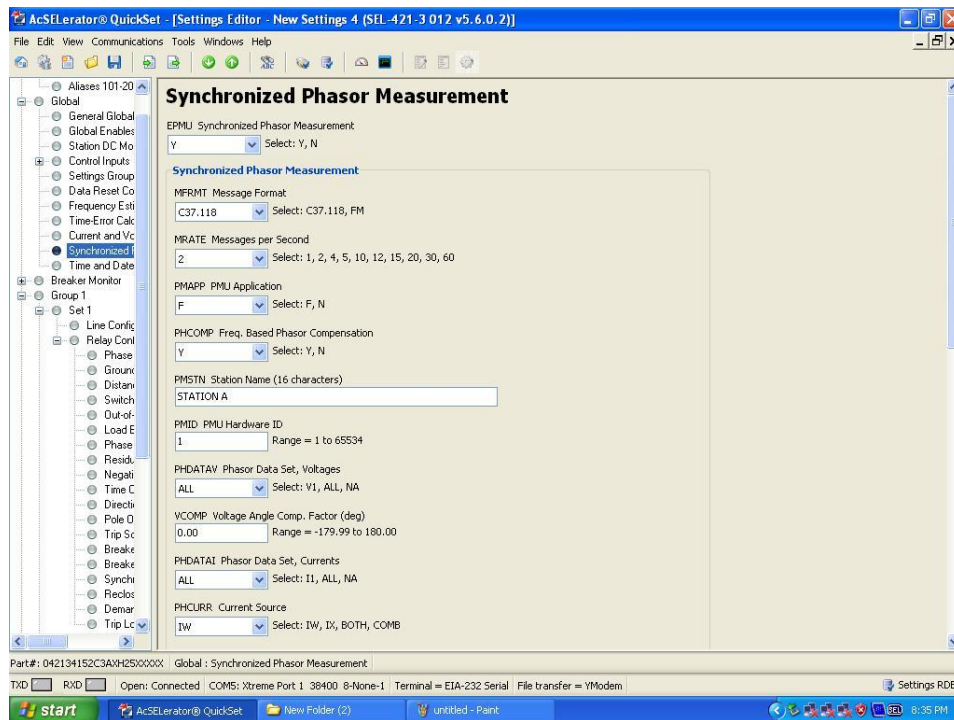

Figure 32: SEL421 synchrophasor phasor measurement