

This is an individual homework.

- 1) (Similar to Assn#1 - Zones of Protection). A "ring bus" arrangement allows one circuit breaker to be taken out of service without affecting the system grid connection. (A one-page explanation of ring buses is given in section 10.7 in your text, and it was explained in class lectures).
- Circle all of the zones of protection in the system given below.
 - What breakers trip for a fault on Line 1?
 - What breakers trip for an internal fault in T1? An internal fault in T2?
 - If CB5 fails to trip for a Line 3 fault, which breaker(s) trip as backup? What are consequences to the operation of the system?
 - If CB4 fails to trip for a fault on L3, what breaker(s) trip as backup? What are consequences to the operation of the system?

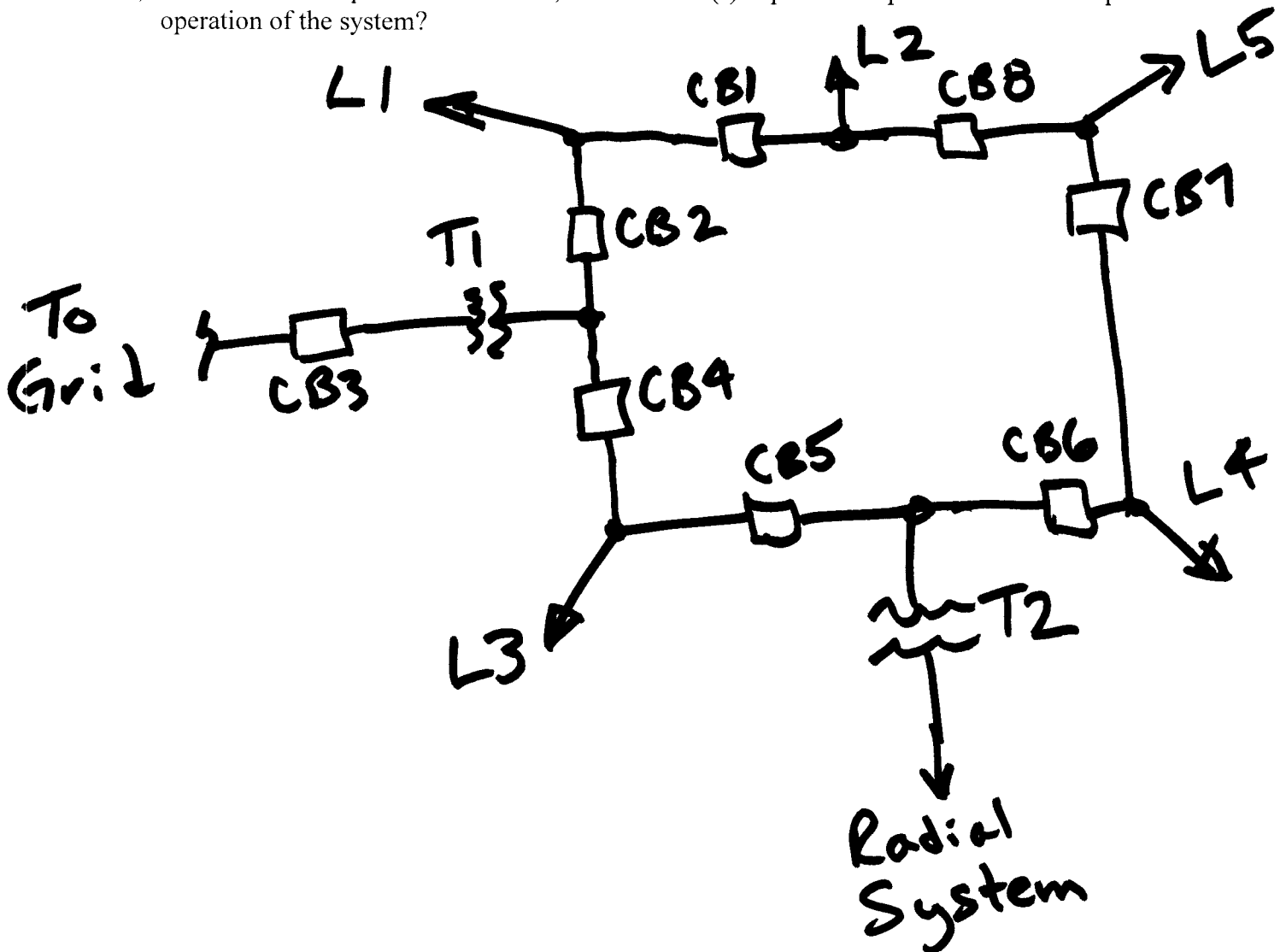

- 2) (Similar to Prob. 3.4 and Section 3.7 of text). A directional overcurrent relay with a 60° unit is used for ground fault protection. Connection is as per figure 3.9 in your text.
- a) A L-G fault occurs on phase C. Assuming the prefault voltage V_A is at 0° , redo the three phasor diagrams of Figure 3.9 to show the voltage and current relationships and to confirm that the relay will see the fault and trip. For this problem, you can assume that a LG fault current will lag the LN voltage of that phase by about $80-85^\circ$ (i.e. there is a high X/R ratio).
 - b) Why are the VTs connected L-N? Would L-L connected VTs work if they were connected properly? If it would not work, explain why. If it will work, sketch out the proper connections of the VTs.

- 3) (Similar to page 2 of 87T Applications Example, Mar 27th on web page). In this case, the transformer is wye on the H side and delta on the X side. H-side Vs and Is lead corresponding X-side Vs and Is by 90°.
- a) Properly sketch out the power connections of the transformer according to the given phase shift.
 - b) Make up the CT secondary connections to the relays so that the phasing of the currents flowing through the Operate and Restraint coils of the relays will not cause a false trip of the relays for normal load current and through faults. .